

ASSEMBLY INSTRUCTIONS

Hampton-D

CONTENTS

Main aluminium parts	P1
End sections	P2
Adding the long rails	P3
End plates	P4
Centre legs	P5
Centre staging rails	P6
Squaring & fixing	P7
Wall & floor problems	P8
Shelving	P9
Watering	P10
Fitting liner	P11
Fitting handles	P12
Fitting glass	P13
Fitting corner trim	P14
Troubleshooting	P15
Notes on using the frame	P16

Please keep all packaging until installation is complete



Video instructions:

Helpful video clips are available at

www.garden-products.co.uk/instructions

Can we improve?

We hope that you find our instructions clear and concise. If you have any suggestions for improvements email:

instructionfeedback@garden-products.co.uk

Access Garden Products
Crick
NORTHAMPTON
NN6 7XS

Tel: 01788 822301
Fax: 01788 824256
sales@garden-products.co.uk
www.garden-products.co.uk

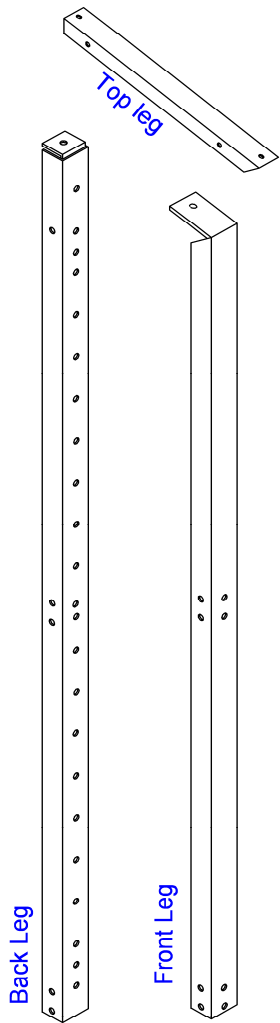
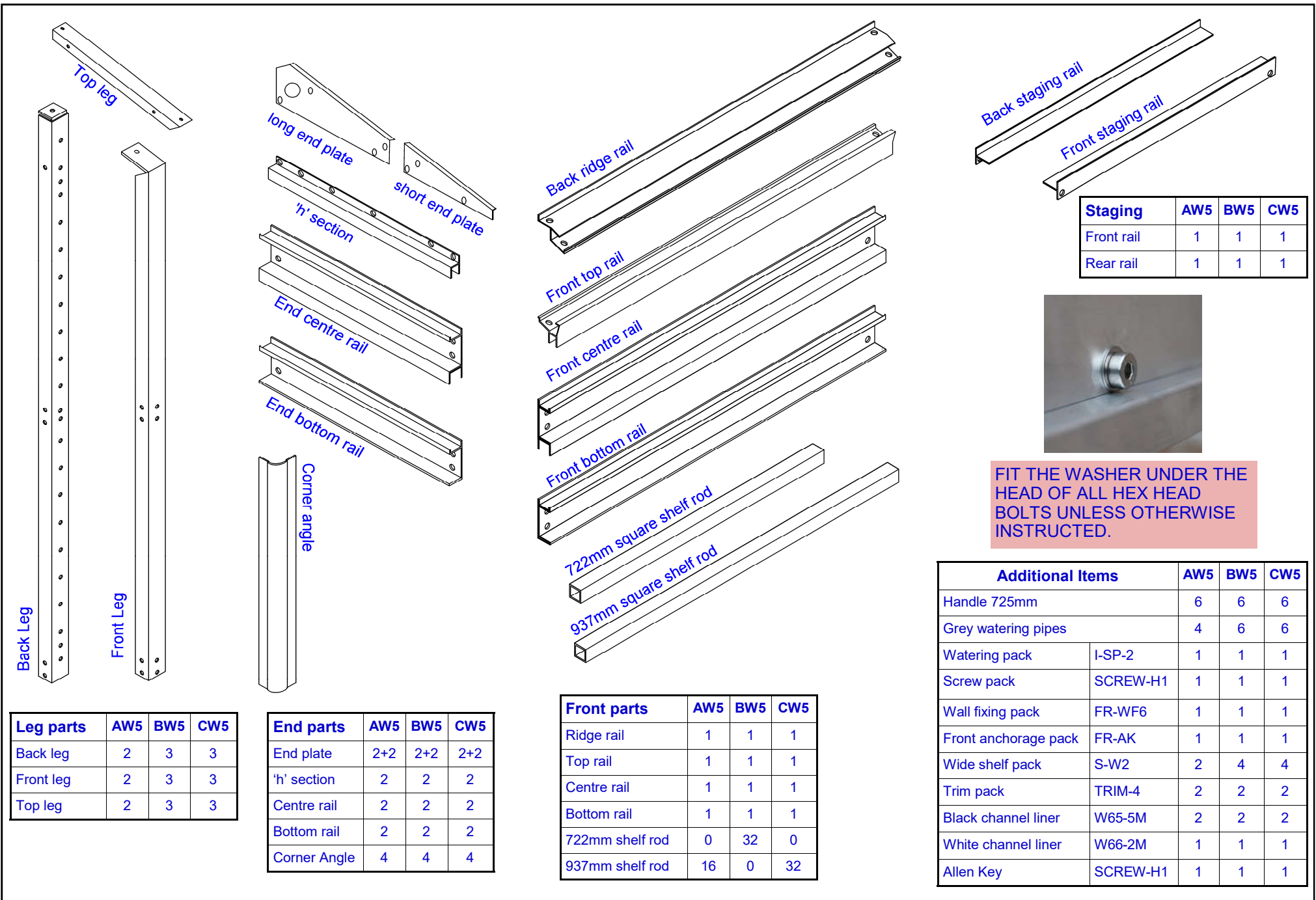

Leg parts	AW5	BW5	CW5
Back leg	2	3	3
Front leg	2	3	3
Top leg	2	3	3

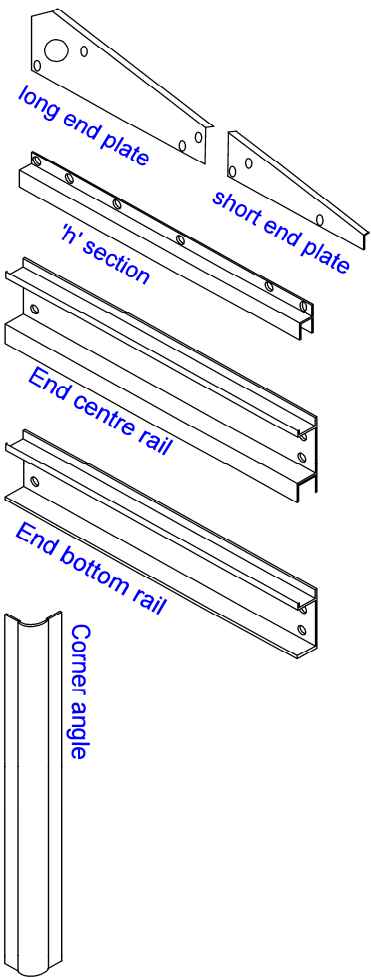

End parts	AW5	BW5	CW5
End plate	2+2	2+2	2+2
'h' section	2	2	2
Centre rail	2	2	2
Bottom rail	2	2	2
Corner Angle	4	4	4

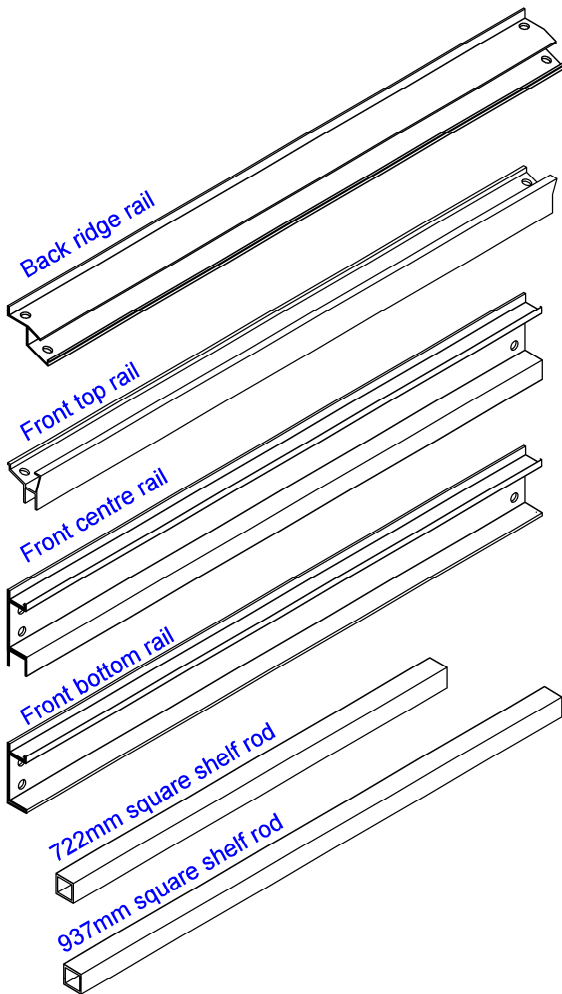

Front parts	AW5	BW5	CW5
Ridge rail	1	1	1
Top rail	1	1	1
Centre rail	1	1	1
Bottom rail	1	1	1
722mm shelf rod	0	32	0
937mm shelf rod	16	0	32

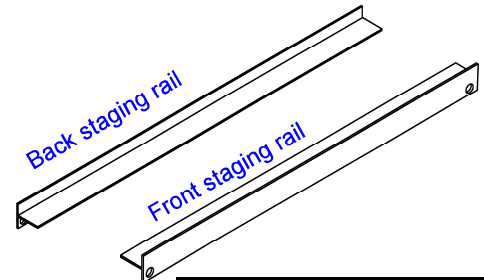

Staging	AW5	BW5	CW5
Front rail	1	1	1
Rear rail	1	1	1



FIT THE WASHER UNDER THE HEAD OF ALL HEX HEAD BOLTS UNLESS OTHERWISE INSTRUCTED.

Additional Items		AW5	BW5	CW5
Handle 725mm		6	6	6
Grey watering pipes		4	6	6
Watering pack	I-SP-2	1	1	1
Screw pack	SCREW-H1	1	1	1
Wall fixing pack	FR-WF6	1	1	1
Front anchorage pack	FR-AK	1	1	1
Wide shelf pack	S-W2	2	4	4
Trim pack	TRIM-4	2	2	2
Black channel liner	W65-5M	2	2	2
White channel liner	W66-2M	1	1	1
Allen Key	SCREW-H1	1	1	1



Top leg rests against the **FLAT FACE** of back leg—it is not bolted to the back leg



Back leg the wrong way round

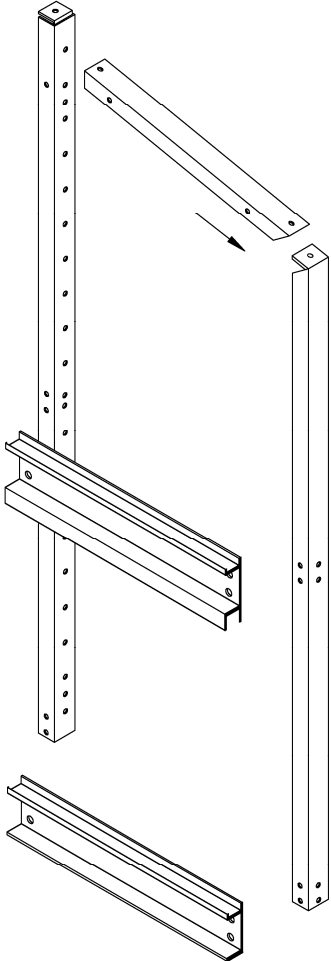

EXPLODED VIEW

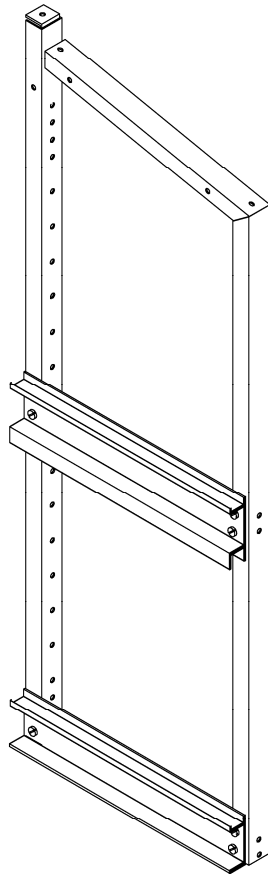

FINISHED LEFT HAND END



Slide the tongue of the front leg into the groove on the top leg.



DEEPER CHANNEL AT BOTTOM

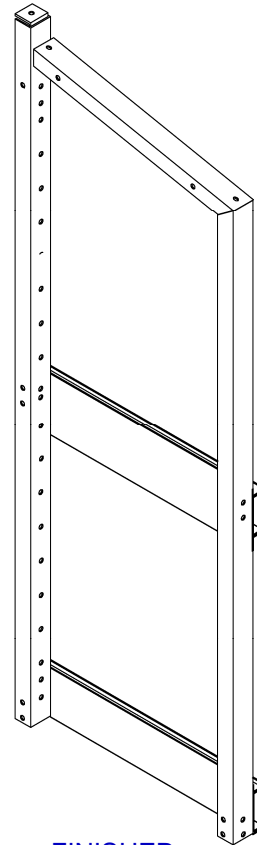

FINISHED RIGHT HAND END

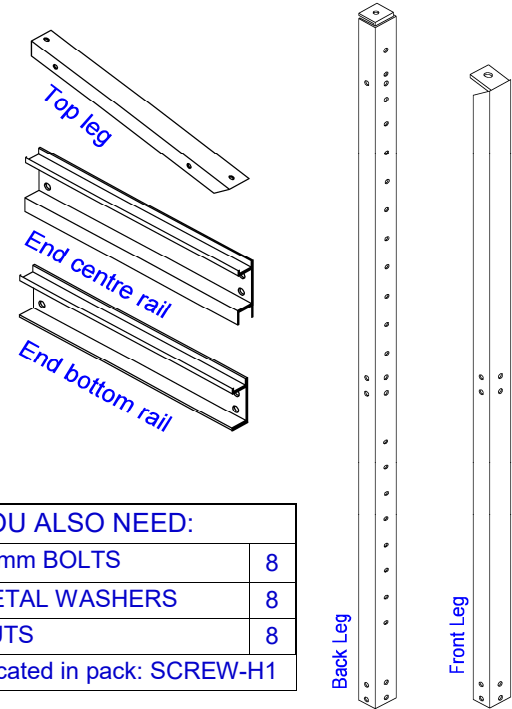

YOU ALSO NEED:

10mm BOLTS	8
METAL WASHERS	8
NUTS	8
Located in pack: SCREW-H1	

PARTS NEEDED FOR EACH END

- 1 Make up the LEFT hand end as shown.
- 2 Make up the RIGHT hand end as shown

DO NOT FULLY TIGHTEN BOLTS AT THIS STAGE



FIXING DETAIL

DO NOT FIT A WASHER AT POINTS MARKED X
ON POWDERCOATED UNITS TAKE CARE NOT TO OVERTIGHTEN THESE BOLTS OTHERWISE THE COATING WILL BE DAMAGED

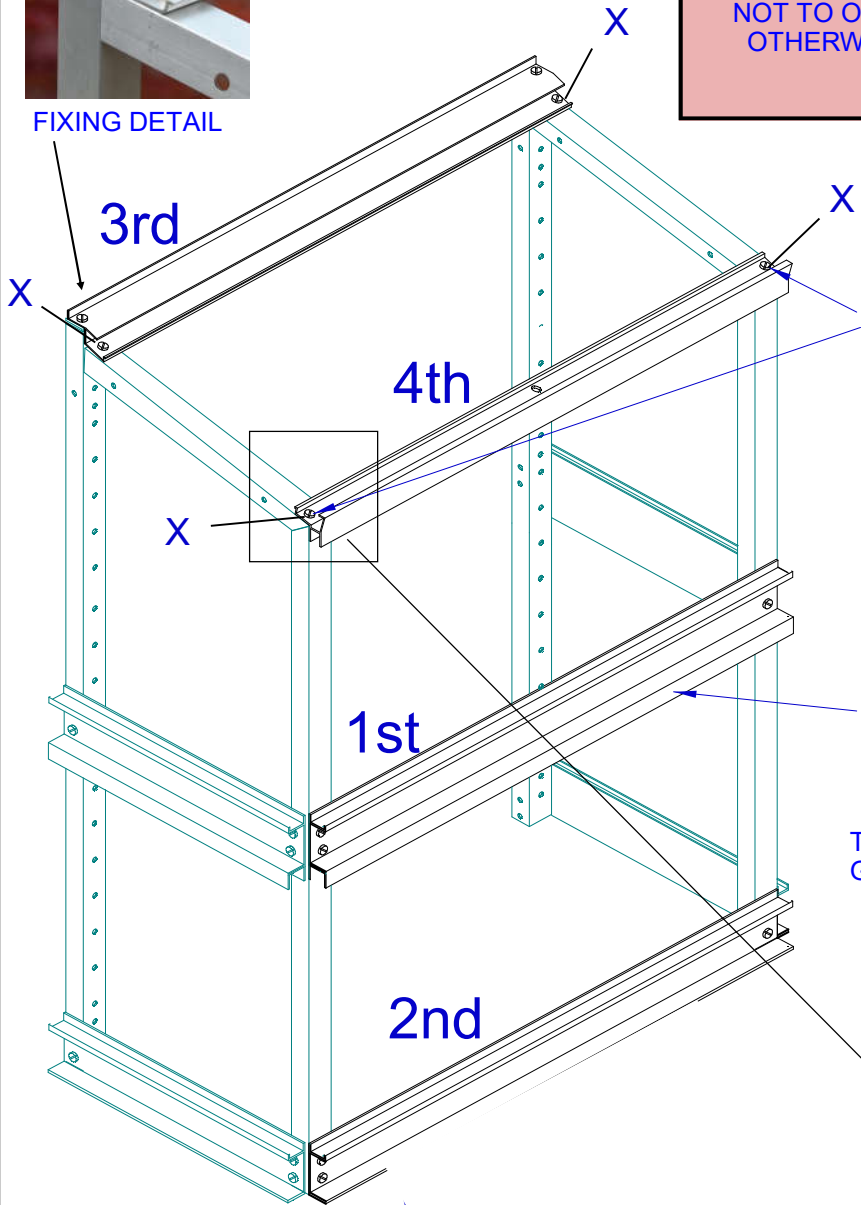

USE THE TWO 20MM BOLTS WITH THIS RAIL



THE DEEPER CHANNEL GOES AT THE BOTTOM



FIXING DETAIL

PARTS NEEDED

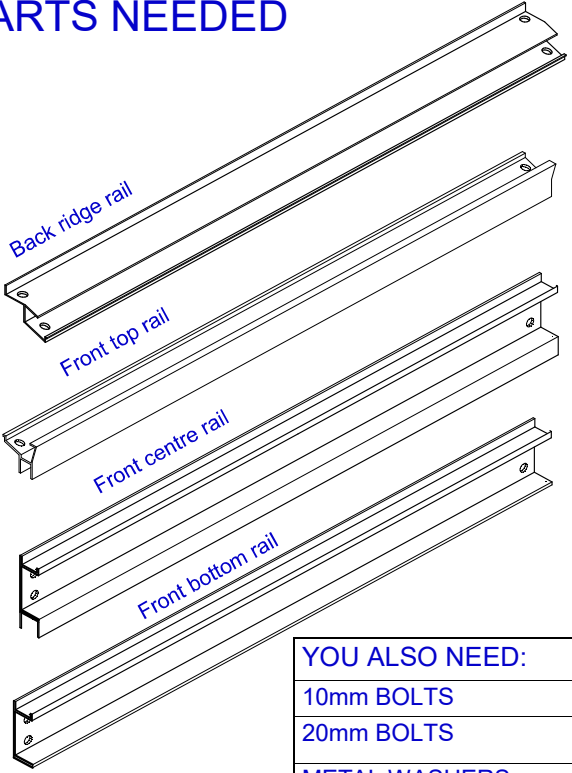

YOU ALSO NEED:	
10mm BOLTS	10
20mm BOLTS	2
METAL WASHERS	8
NUTS	12
Located in pack: SCREW-H1	

1 Bolt on the rails in the order shown.

DO NOT FULLY TIGHTEN BOLTS AT THIS STAGE

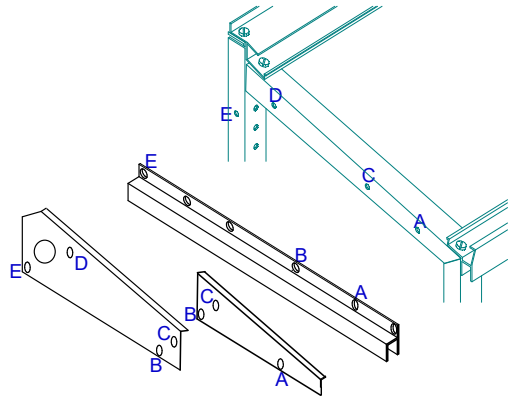

EXPLODED VIEW
LEFT HAND END

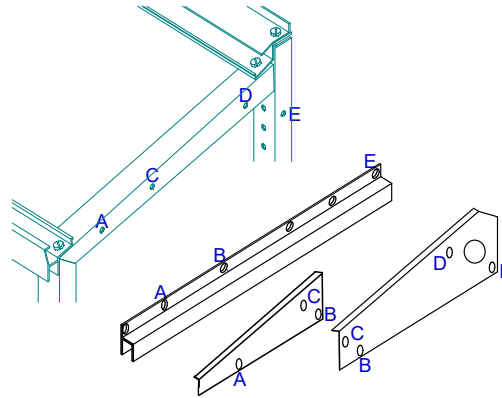

EXPLODED VIEW
RIGHT HAND END

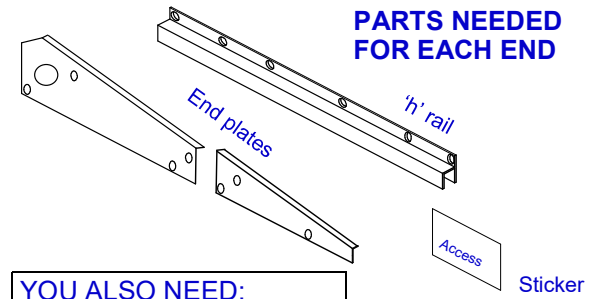

YOU ALSO NEED:

10mm BOLTS	5
METAL WASHERS	5
NUTS	5
Located in pack: SCREW-H1	



THE END PLATE
FITS UNDER THE
RIDGE RAIL LIP

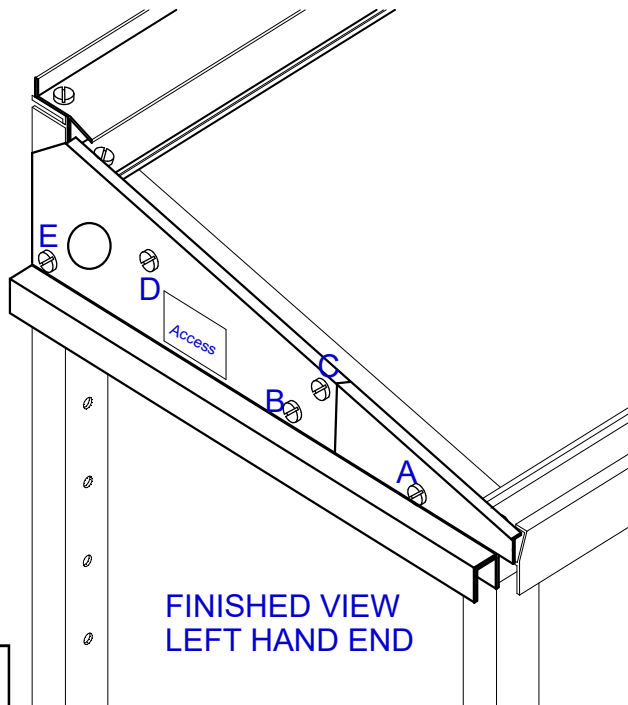

FINISHED VIEW
LEFT HAND END



THE END PLATE
FITS UNDER THE
FRONT RAIL LIP

- 1 **Remove any plastic protective film** from the end plates and put 'Access' sticker on the large end plate.
- 2 To make the left hand end: Bolt the two end plates and the 'h' section together using bolt 'B'. The long end plate fits on the outside of the short end plate.
- 3 Bolt the assembly onto the frame using bolts 'A' and 'E'. Fit bolts 'C' and 'D'.
- 4 Repeat for the other end.

IF YOU HAVE AN
AW5 MODEL
GO TO PAGE 6

DO NOT FULLY TIGHTEN
BOLTS AT THIS STAGE

DO NOT FIT A WASHER AT THE 2 POINTS MARKED X IF POWDERCOATED TAKE CARE NOT TO OVERTIGHTEN BOLT AS WILL DAMAGE PAINT

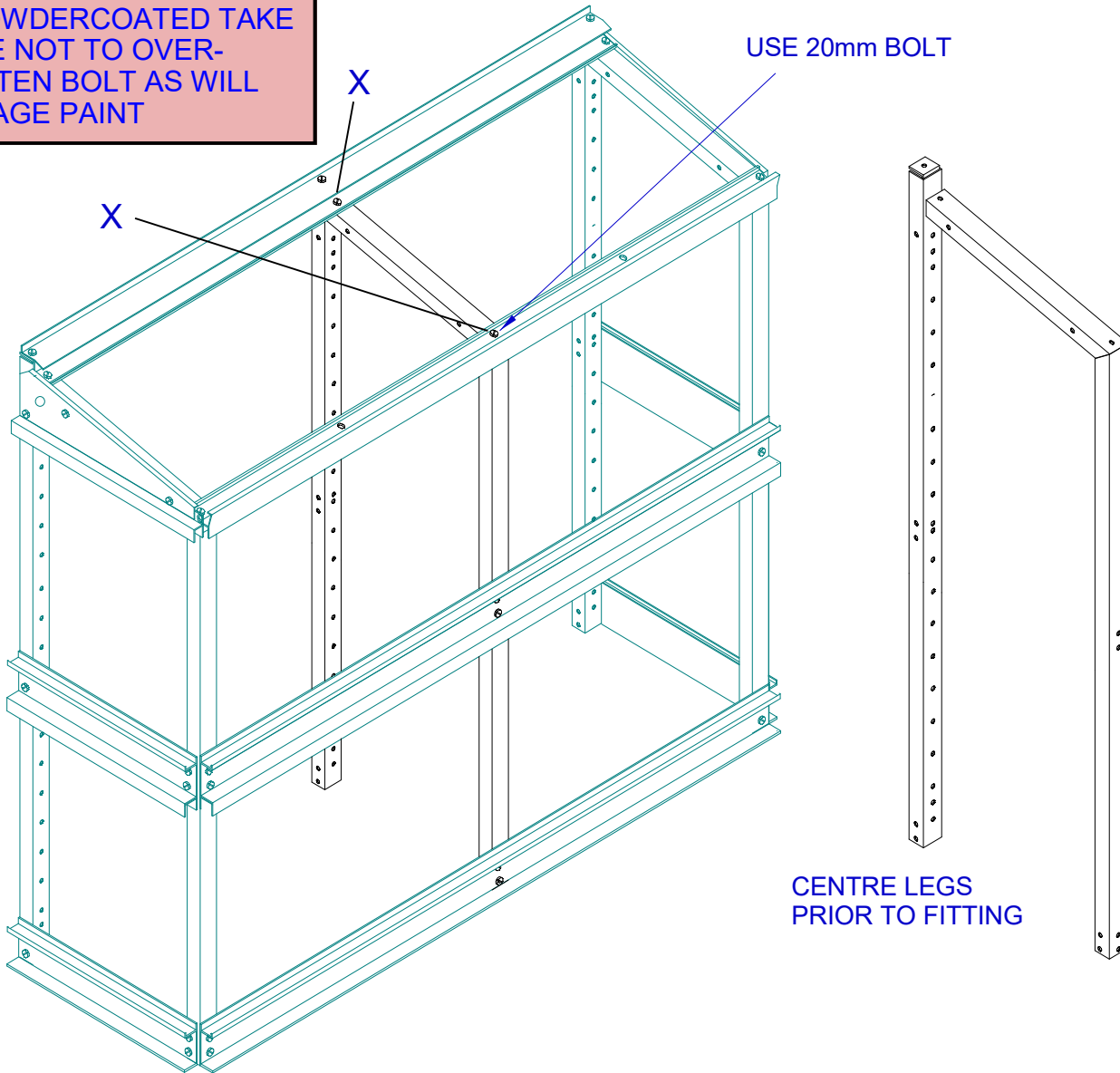

PARTS NEEDED

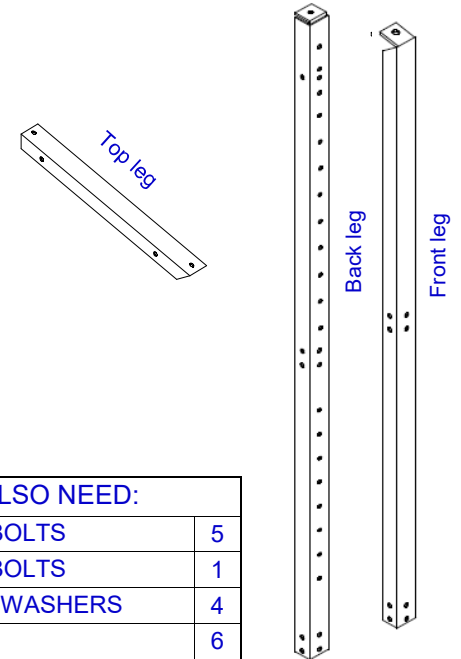

YOU ALSO NEED:

10mm BOLTS	5
20mm BOLTS	1
METAL WASHERS	4
NUTS	6
Located in pack: SCREW-H1	

1 Fit legs as shown into the frame.

DO NOT FULLY TIGHTEN BOLTS AT THIS STAGE

PARTS NEEDED AW5 MODEL

YOU ALSO NEED:	
40mm BOLTS	2
NYLON SPACERS	2
METAL WASHERS	2
NUTS	2
Located in pack: SCREW-H1	

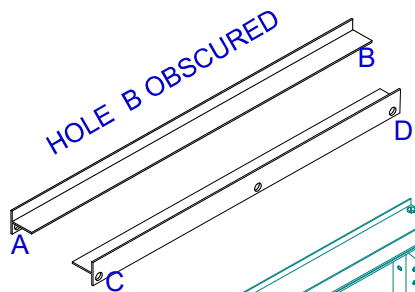

Centre staging rails must have fixing bolt holes on the underside

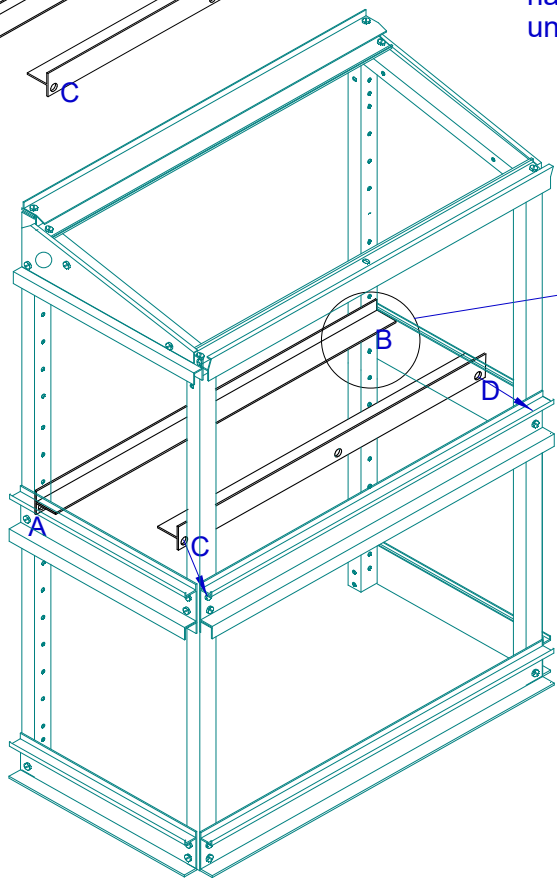

BOLT TO THE 12TH HOLE FROM THE FLOOR

1

POSITION THE RAILS INSIDE THE FRAME AS SHOWN. BOLT THROUGH HOLES SHOWN

Front rail: Replace the upper 10mm bolts on the front centre rail with 40mm long bolts. Slide on nylon spacers, then the front staging rail before refitting the nuts.

Back rail: The 10mm bolts removed from the front rail will be needed to fix the back staging rail. Fit the rail using the 12th hole from the floor.

PARTS NEEDED BW5 & CW5 MODEL

YOU ALSO NEED:	
40mm BOLTS	3
NYLON SPACERS	3
METAL WASHERS	3
NUTS	3
Located in pack: SCREW-H1	

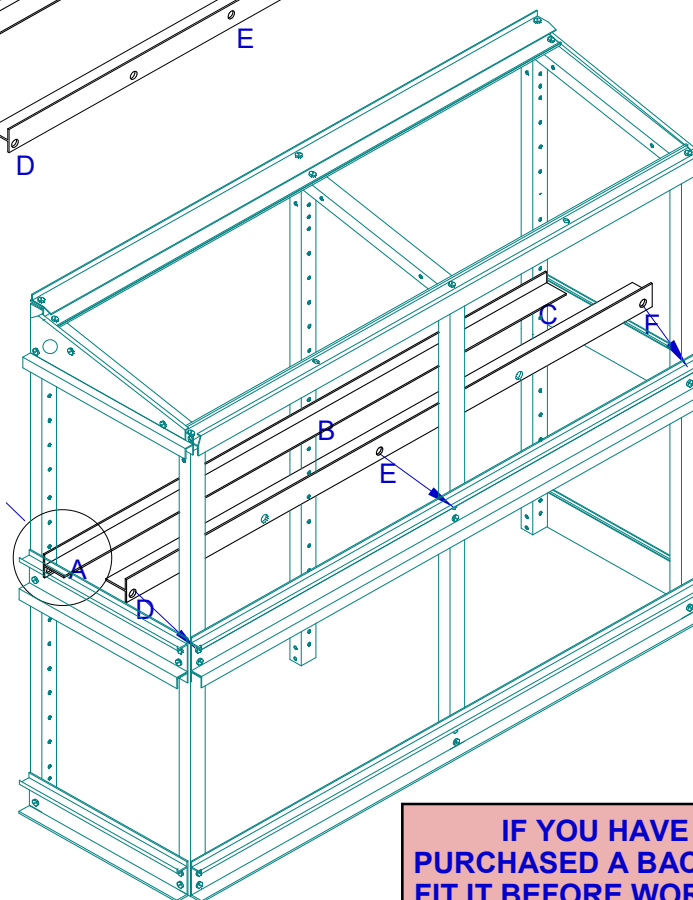
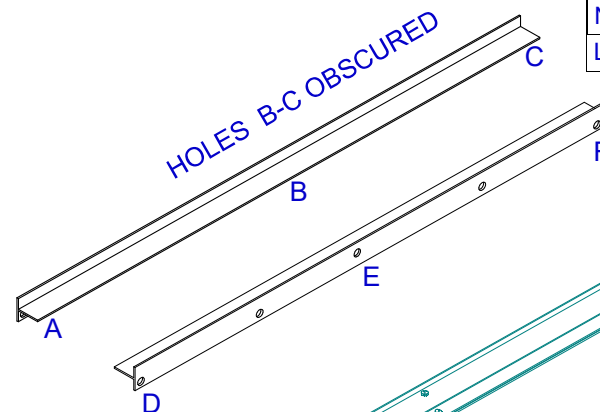

IF YOU HAVE PURCHASED A BACK KIT FIT IT BEFORE WORKING ON THIS PAGE

1

SQUARING THE FRAME

Use a set square (or the A5 frame squaring card provided) to square the unit up in the 3 places shown.

IT IS ESSENTIAL TO GET THE FRAME SQUARE. DO NOT ALIGN TO THE WALL AS IT MAY NOT BE SQUARE .

Ensure distance 'A' is equal to distance 'B' otherwise the shelves will not fit.

Once the frame is completely square tighten up all the nuts.

FIXING TO WALL

Two hammer fix screws are used in each 'back leg' (pack FR-WF6).

Counting from the floor the screws go in the holes marked 'F'.

2

Holes 2 & 23

Using a 6mm masonry bit drill, mark the drill at a depth of 65mm. With the unit against the wall, drill through the holes (F) until the mark reaches the hole in the 'back leg'. Push the COMPLETE screw and rawlplug through the hole in the back leg and into the wall.

Lightly hammer or screw in with a 'phillips head' screwdriver.

FULLY TIGHTEN ALL BOLTS

If this nut turns while tightening, use a small pair of pliers to hold the nut

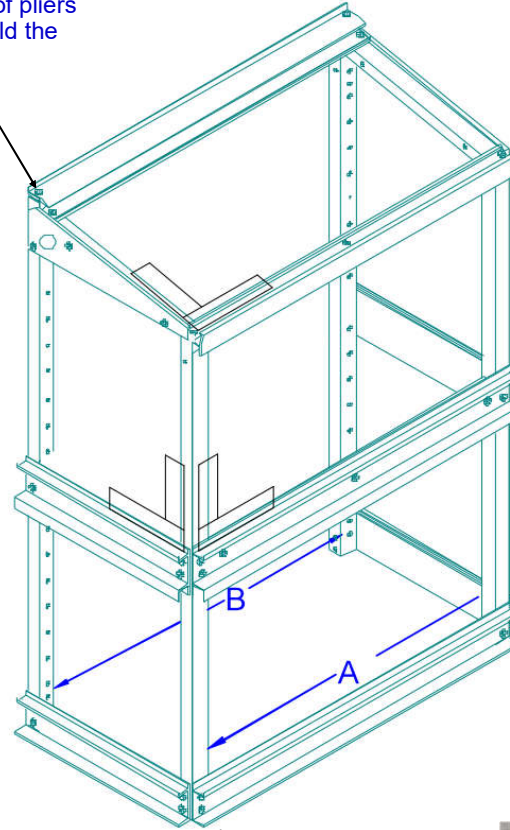

PARTS NEEDED

Front anchorage pack	FR-AK
Wall fixing pack	FR-WF6

3

FRONT FIXING TO FLOOR

Once the unit has been fitted to the wall the front anchorage kit (pack FR-AK) can be fitted.

Fit the 'L' bracket to the front leg using a nut and bolt.

Drill through the bracket with a 6mm masonry drill bit, to a depth of 35mm. Insert the red rawlplug, through the bracket and into the concrete.

Using woodscrew, screw through the 'L' bracket and into the rawlplug.

Repeat for other end.

On BW5 model fit an 'L' bracket to the centre leg. Ensure that the front rail is not bowed before fixing, otherwise the centre staging sheets will not fit. A centre staging sheet can be used to check - see page 13.

WEAR APPROPRIATE SAFETY EQUIPMENT WHEN DRILLING OR HAMMERING

TIP: If your drill is touching the framework, just mark the holes, then remove the frame to allow the holes to be drilled.



INSIDE VIEW OF FRONT LEG SHOWING FRONT FIXING

FLOOR FALLING AWAY

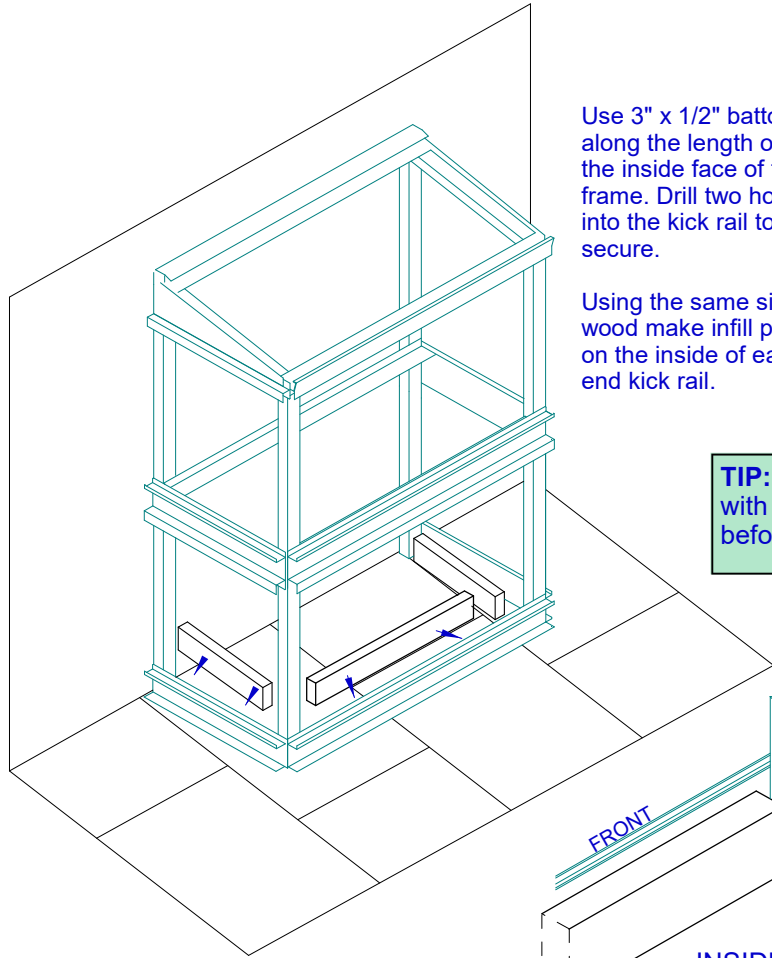

Use 3" x 1/2" batton along the length of the inside face of the frame. Drill two holes into the kick rail to secure.

Using the same size wood make infill pieces on the inside of each end kick rail.

TIP: Always treat timber with wood preservative before fixing in place

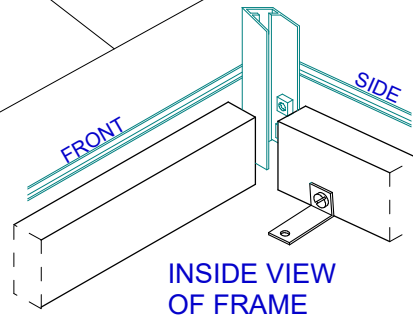

Screw or bolt 'L' shaped brackets to the wood and then to the floor

ROUGH OR SLOPING WALL

To solve problems with walls choose option A or B below. Fit the frame to the woodwork using 1.25" wood screws. (not supplied) Seal around the inside of the frame with silicone sealant when finished.

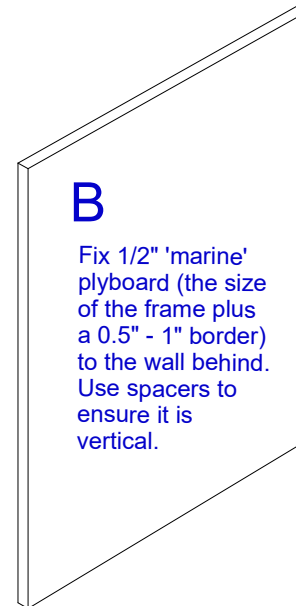

B

Fix 1/2" 'marine' plyboard (the size of the frame plus a 0.5" - 1" border) to the wall behind. Use spacers to ensure it is vertical.

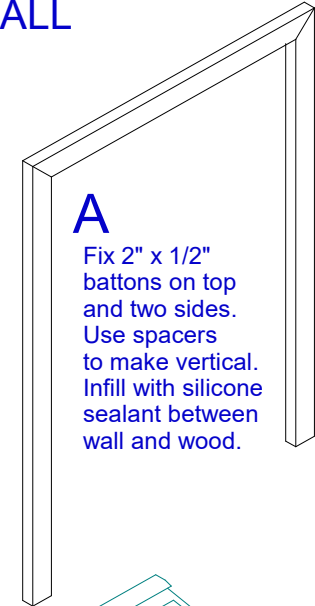

A

Fix 2" x 1/2" battons on top and two sides. Use spacers to make vertical. Infill with silicone sealant between wall and wood.

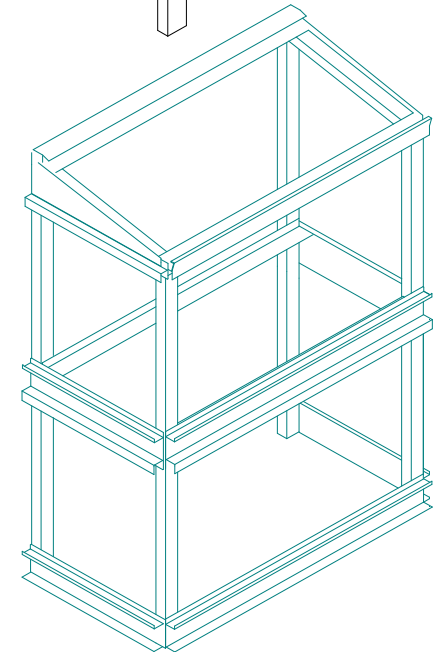

The AW5 model has 4 wide full length shelves.

The BW5 & CW5 models have 8 wide half length shelves.

- 1 Lightly tap rawplug inserts into both ends of the tubular aluminium shelf rods with a hammer.
- 2 Screw the support brackets on to each end EXCEPT for the rod that has the support wires.
- 3 For the rod with the support wires put the spacer and the support wire onto the screw BEFORE passing through the bracket.

FITTING



wide shelves:
miss one hole

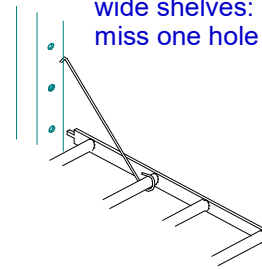

Hook support wire into top hole, then swing shelf upward into the hole. Make sure flat face of shelf rod is uppermost.

PARTS NEEDED

Square rod profile
Flat face is uppermost

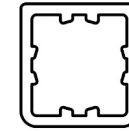

Shelf rods

support wire

support bracket

YOU ALSO NEED PER SHELF ROD:

RAWLPLUG	2
WOOD SCREW	2
Located in packs: S-W2	

YOU ALSO NEED PER COMPLETE SHELF:

NYLON SPACER	2
Located in packs: S-W2	

NEW 5-hole strap

Fit the rods to the holes 'F' - the rod with support wire is marked SW. The centre hole is unused.

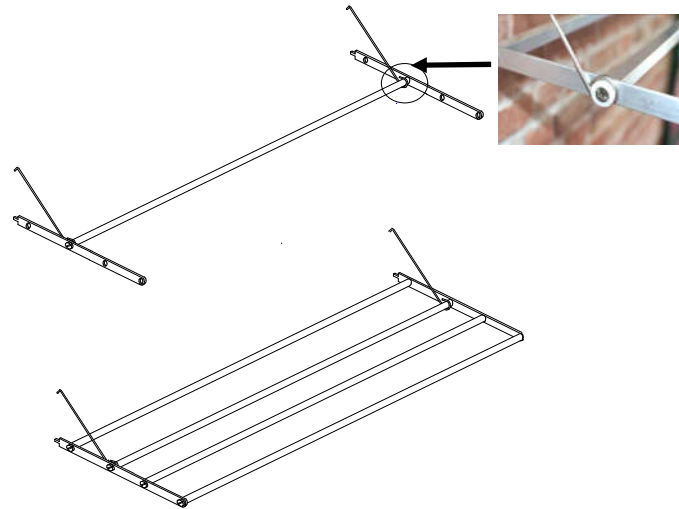
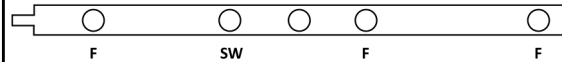

Note: A Pozidrive screwdriver will fit the screws best

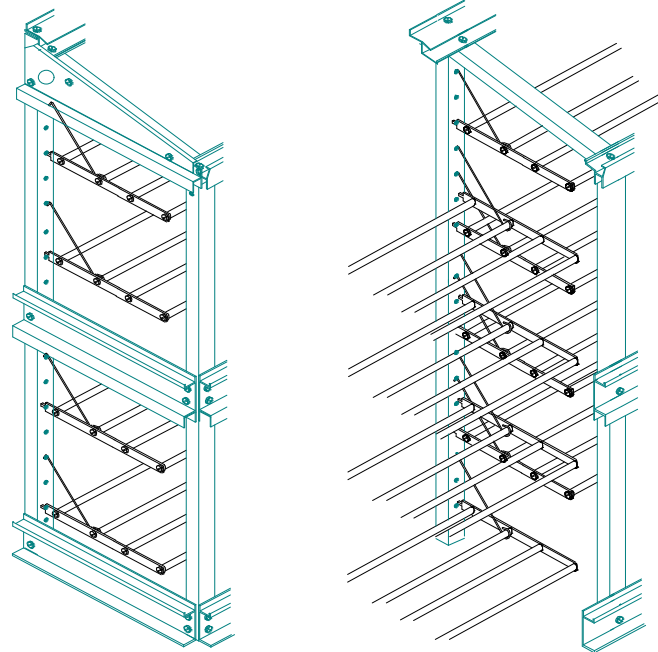

HALF LENGTH SHELF FITTING

Support wires can share same hole as support bracket



The large number of holes in the back leg allow the spacing of the shelves to be easily altered.

When the shelves are not needed they can either be removed or they can be unhooked from the lower fixing hole and hung flat against the back using the wires.



Bottom shelf hung flat against the back

1 Choose which end you would like the watering inlet.



Fit the washer onto the thread of the adaptor, and then fit the nipple

Push the assembly through the hole from the inside

Screw the brass elbow onto the protruding thread from the outside

Right hand watering entry:
The double tee is configured for fitting to the left hand end. To change to r/h entry, twist the tee through 180 degrees.

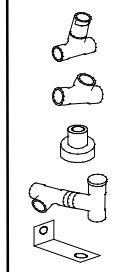
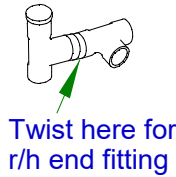

PARTS NEEDED:		
NOZZLE ASSEMBLY (I-W-NA)	AW5 BW5/CW5	2 4
SINGLE TEE (KET)		2
BLANKING PLUG (KEB)		4
DOUBLE TEE (I-W-CP)		1
'L' BRACKET	AW5 BW5/CW5	2 4
GREY PIPES	AW5 BW5/CW5	4 6
ENTRY FITTING: Nipple, adaptor, washer and brass elbow		1
10MM BOLTS & NUT	AW5 BW5	2 4
BLACK STRAPS (short)		6
BW5/CW5 (long)		1
Located in pack: I-SP-2		

2 'L' brackets need to be fitted inside the frame. x - Use a nut and bolt to fix to the hole y - Use the bolt hole on the centre staging rail

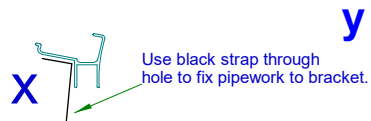
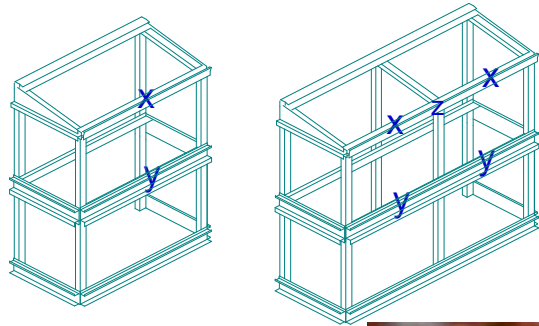

Use black strap through hole to fix pipework to bracket.



Bend bracket down

3 Fit the irrigation system as shown. The grey tubes push into the black fittings. Ensure the open face of the grey nozzle faces into the frame.

TIP: Dip the end of the grey pipe in water. For a better fit, twist the pipes as they are inserted.

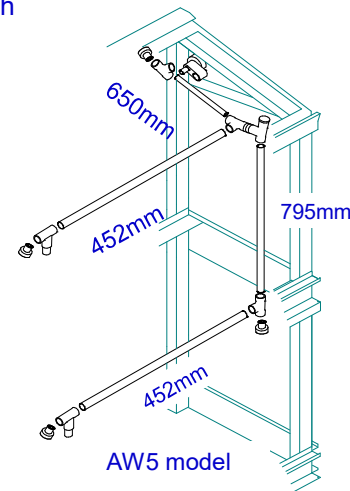

AW5 model

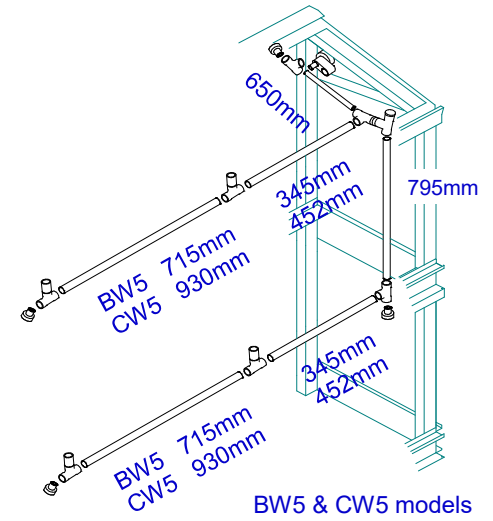

BW5 & CW5 models

4 Use the black straps to secure the watering system to the 'L' shaped brackets and then strap the pipes to the end of the frame using the hole in the leg. The long strap is used to secure the pipe to the top leg at position 'Z' (BW5).

Fit the black grommet (from pack SCREW-H1) into the unused irrigation hole at the opposite end of the unit.



Blanking grommet



Inlet and link pipe



Double tee



Nozzle strapped to 'L' bracket

FITTING THE CHANNEL LINER

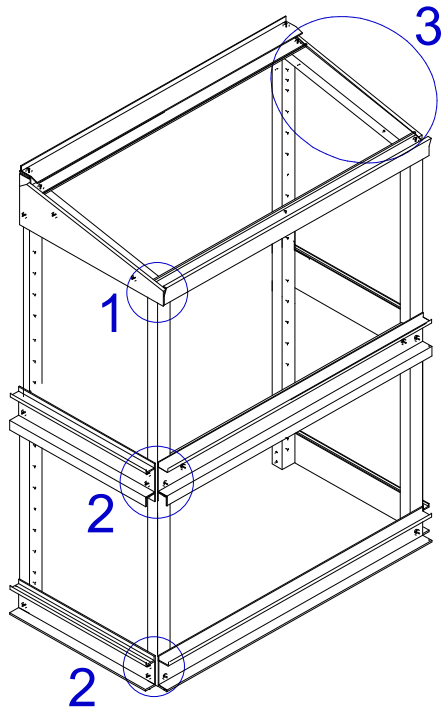

Before sticking the tape, clean the aluminium of any oil traces to promote adhesion.

TIP: Do not use the red covered sticky pads that are for the handles

1 The white liner (W66-2M) fits on the inside vertical face of top FRONT rail only. This is a loose fit so strips of double sided tape are included to secure it until the glass is in place.

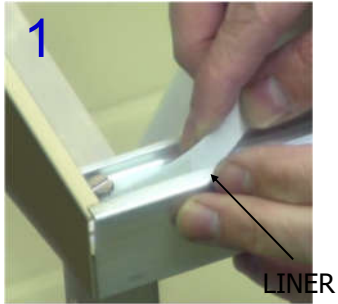
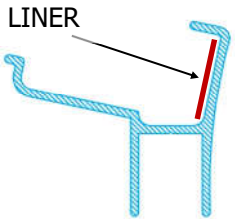

2 The black plastic liner (W65-5M) goes in the FRONT bottom and centre rails only. Using the strips of double sided tape press liner down so that it LIES FLAT at the bottom of the channel - trim with a knife if necessary.

THE DOORS WILL NOT SLIDE PROPERLY IF THE LINER IS NOT FLAT

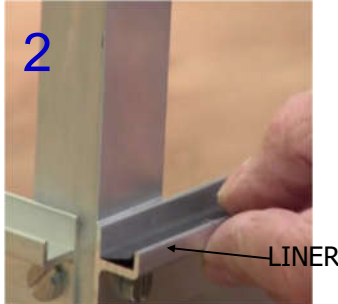

3 To make the top glass slide more easily, rub candle wax onto the glass bearers. Also wax the black and white liners.

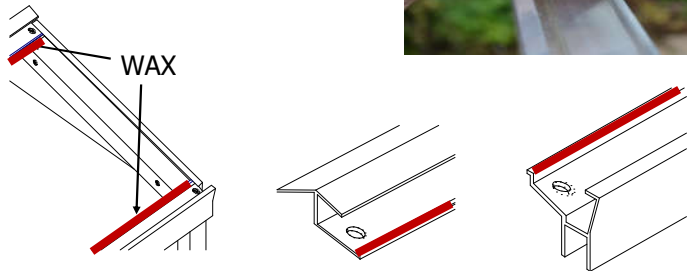

Removing the tape

Peel the **narrower** backing tape off first, this will expose the sticky pad, allowing it to be stuck onto the liner.

Tip: Bend the backing tape back on itself to make it easier to peel the sticky pad off.

Place pads regularly down the length of the liner.

When ready, peel the **wide** backing pads off the tape and stick the liner to the aluminium.



On the next page are instructions on how to fit the handles to the glass

When fitting the handles, place the glass on a table or timber battens.

NEVER PLACE THE GLASS DIRECTLY ON CONCRETE OR SLABS

DO NOT lift the glass by the handle

If possible, leave the handles overnight in a warm place to promote the curing of the adhesive

TIP: Always grip the handle in the **CENTRE** when sliding

WARNING

If broken, toughened glass will fragment safely.

If the edges are knocked or chipped the glass will spontaneously fragment. This is a natural occurrence due to the toughening process. Care should be taken when moving or cleaning, not to damage the edge of the glass.

When placing the glass in the frame, ensure that the glass is securely placed in the runners before letting go of the glass.

SEE PAGE 14 FOR WHICH GLASS SHEETS NEED HANDLES	'C' sheet
Sheets requiring one handle	2
Sheets requiring two handles	2

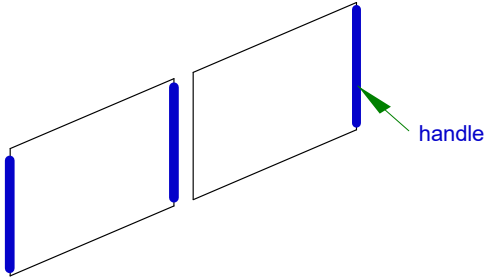

HANDLES

The right hand glass sheets always have 1 handle.

The left hand glass sheets always have 2 handles.



Work on handle from side edge



Handle fitted with 15mm gap



Sheet with 2 handles

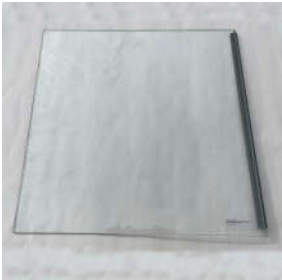

Sheet with 1 handle

FITTING THE HANDLES



1

Ideally work on a table or a workbench.

It is best the work inside to keep the pads warm and dry.



2

Mark the glass 15mm from the top edge for sheets.



3

Open the sachet and wipe the glass where the tape will stick.



4

Replace the cloth in the plastic bag to prevent evaporation.



5

Peel the pad off the backing.

Each handle has 3 pads (top, middle and bottom of handle).

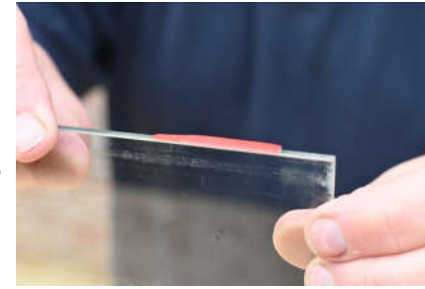

6

Press the pad down firmly to ensure good adhesion to the glass.

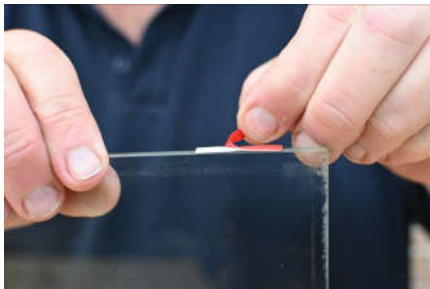

7

Peel the cover strips off all of the pads.



8

Using the pen mark as a guide, fit the handle.

Slide the two arms of the 'U' over the edge of the glass.



9

Work the handle on with your hands.



10

Use one of the glass battens to gently tap the handle down.



11

Work the handle on all the way down the glass.

Use the timber batten if necessary.



12

Use the timber to make sure the handle is flat.

Leave overnight in the warm to fully cure the adhesive

CENTRE STAGING (D)

If you wish to fit the centre staging glass (453mm x 700mm) sheets place these on the centre staging rails before glazing the frame. Centre staging is in glass packs GT-SWA or GT-SWB.

FITTING HANDLES

Fit the handles to the glass before fitting into the frame. Right hand panels always have a single handle on the right hand side of the sheet. Left hand panels have two handles, one on each side.

FITTING THE GLASS

To fit the glass push the sheet into the deeper top channel, then lower into the bottom channel (A). Make sure the glass is firmly in the bottom channel before letting go. When putting the sheets in the frame, put the first sheet in at the right hand end. The second sheet will fit in front of the first sheet and overlap the first panel by approx. 1" (2cm).

SLIDING THE FRONT GLASS

When closed, both panels will tuck behind the corner trims to keep them secure. Before sliding the right hand panel open, slide the left hand panel open by approx 1" to release it from behind the corner trim.

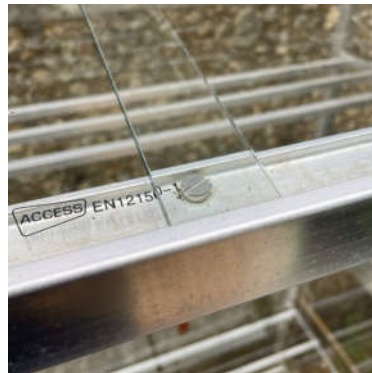
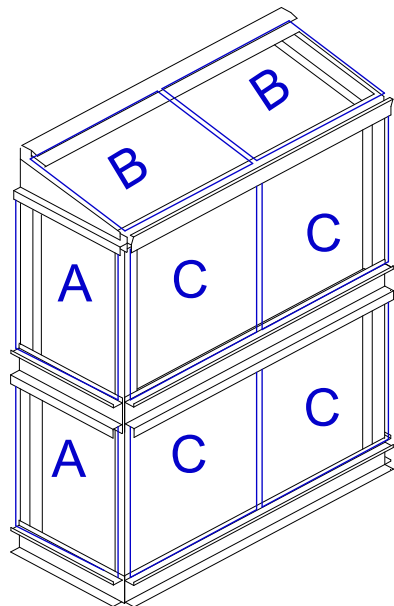

Roof glass overlapping



Glass in channel with two sheets overlapping



D. Centre staging fitted



A. Fitting the glass

AW5 3'4" Hampton-D			BW5 5'0" Hampton-D			CW5 6'5" Hampton-D		
A	750mm x 750mm	Qty: 4	A	750mm x 750mm	Qty: 4	A	750mm x 750mm	Qty: 4
B	750mm x 500mm	Qty: 2	B	750mm x 500mm	Qty: 3	B	750mm x 500mm	Qty: 4
C	750mm x 500mm	Qty: 4	C	750mm x 750mm	Qty: 4	C	750mm x 965mm	Qty: 4
D	453mm x 700mm	Qty: 2	D	453mm x 700mm	Qty: 3	D	453mm x 700mm	Qty: 4
Top and end glass (A & B) have no handles								

BLACK 'WEDGES'

The small black thimble wedges (w) are designed to be pushed into the top channels of the end glass to stop the glass moving. Use two wedges per sheet of glass



Located in pack: SCREW-H1



Corner trim in place

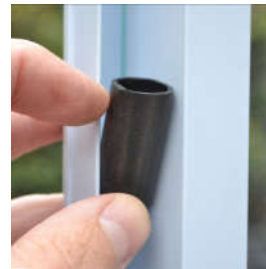
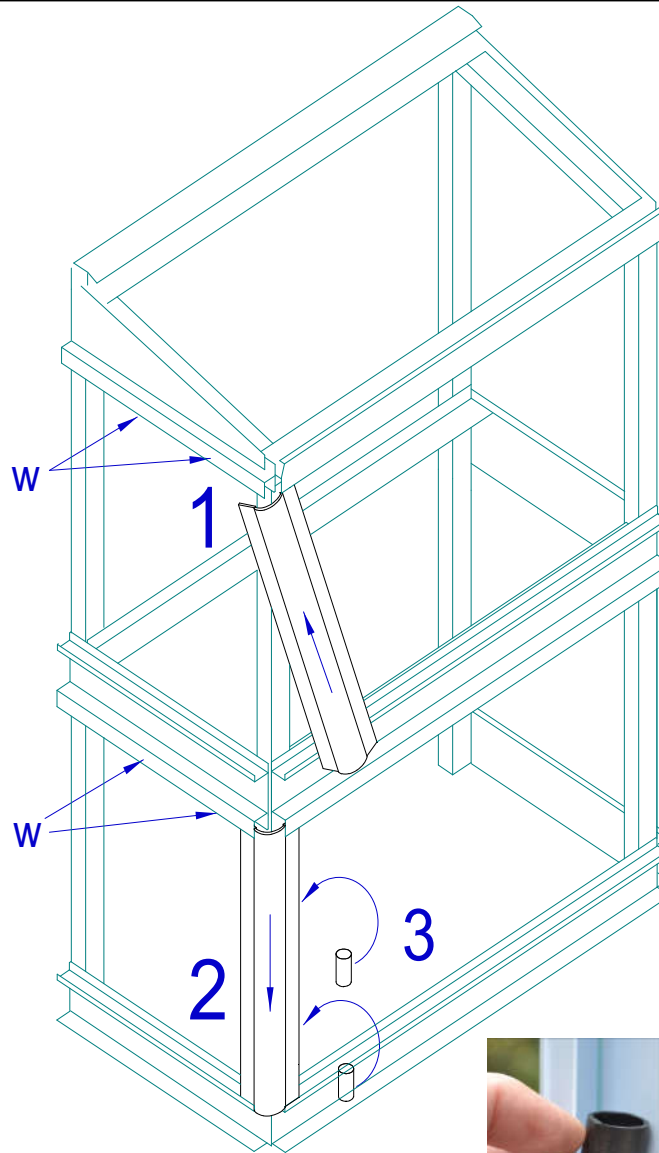

Fitting the hollow tube

Aluminium corner trims

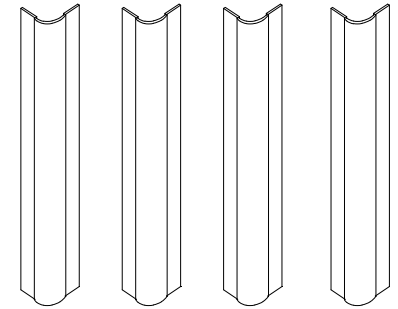

You also need: 2 bags marked as TRIM-4 x 2

PARTS NEEDED



- 1 Take one of the corner trims and push it up into the top channel and the 'h' section.
- 2 Swing the corner trim in so that it is vertical and drop it into the channel below. At this point the trim will be loose.
- 3 Slide the front glass door out of the way. Take one of the hollow tubes contained in the pack marked 'TRIM'. From the front of the frame, push the tube between the framework and the corner trim. Slide the tube downwards as far as it will go.

Insert a second hollow tube and repeat the action, but this time push the tube up as far as it will go.

These tubes keep the corner trim firmly in place, and act as a stop for the sliding doors.
- 4 Repeat for the other 3 corners at the back.

CORNER TRIMS WILL NOT FIT	The most common cause of this problem is the end glass protruding over the front leg. This is normally caused because the frame work is not square against the wall. See page 7.
GLASS STICKS TOGETHER	This is normally due to the handles not being put on the right side of the glass. See page 12 for details of where the handles should be fitted to the glass. If the glass has stuck together, push the two sheets to the back of the channel, then slowly pull the front sheet of glass forward from one end. This will release the suction between the sheets.
HANDLES COME OFF	If handles come off frequently either purchase some new handles and sticky pads from Access or use a glue such as 'liquid nails' or 'no more nails' to permanently glue the handles to the glass.
SHELVES WILL NOT FIT INTO THE BACK LEGS	Check that the back legs have been fitted the right way round - see page 2. Check that dimension A = B - see page 7.
LOUVRE VENT DOES NOT FULLY CLOSE ON COLD DAYS	Loosen the two screws which hold the automatic opener to the vent. Push the opener up as far as it will go. Retighten the 2 screws. If the unit still does not fully close, lubricate the opener mechanism and all the pivot points with WD-40
GLASS FALLS OUT OF THE LOWER LEVEL	Ensure that the centre rail has the deeper channel at the bottom.
WATERING INLET LEAKS	Try tightening the inlet fitting as it needs to be tight to seal.

PERIODIC MAINTENANCE

Every Spring take the glass out of the greenhouse and wash glass and framework with warm soapy water.

Lubricate the automatic louvre vent bi-monthly and remove if subject to very heavy frosts.

When inserting the glass, always check that the glass is properly seated in its top and bottom channels before letting go of the sheet.

CHECK THE TIGHTNESS of all bolts regularly, especially in very windy areas or powder coated frames.

CROP ROTATION Suggestions for suitable crops and sowing dates given in the free Access Growing Guide

VENTILATION In cold weather gentle ventilation can be given by sliding the four front sheets of glass to give 2-3" (5-8cm) gap at each corner.

In warmer weather allow a gap on the top sheets as well. In very hot weather open all the sheets of glass.

To ensure that the correct temperature is maintained use a thermometer inside the greenhouse. You can completely remove the top sheets in summer. Access shading will help keep temperatures down, and stop birds etc getting inside. The Access Automatic Vent will look after ventilation - automatically!

GALES The greenhouse must be kept fully closed in rough weather.

GLASS CHANNELS Ensure that this is kept free from debris and allows the glass to slide smoothly. Periodically lubricate the running edge of the glass with a wax candle.

SNOW If snow is very heavy - avoid letting it build up on the roof

SHELVING Stand pot plants on saucers, or use optional shelf covers which incorporate a layer of capillary matting to absorb excess water when watering. Alternatively, stand the pots in empty seed trays.

CENTRE STAGING To accommodate tall plants slide one sheet over another or lift out completely.

WATERING SYSTEM The system accepts standard quick connectors. Turn the tap on slowly until the mist fills the greenhouse; too much pressure will throw water on to the back wall. Leave on for 5 minutes, or ½ minute for damping down.

SITING Site on the sunniest place available. Anything from East through South to West is suitable. If it has to face North, don't despair, it will be warmer in than outside! If you can fix to a brick or stone wall, you will get extra heat storage during the day.

REDUCING THE LENGTH If it is just too long for your ideal spot, it can be shortened. Re-drill the holes at one end of the rails - moving them in by the amount you need to remove. Hacksaw off the surplus aluminium and shorten the shelf rods and irrigation pipe. The glass will merely overlap more - don't try to cut toughened glass!