

# ASSEMBLY INSTRUCTIONS

## City Growhouse

### CONTENTS

Main aluminium parts	P1
End sections	P2
Adding the long rails	P3
End plates	P4
Squaring & fixing	P5
Centre & lower back rails	P6
Centre staging rails	P7
Infill panel	P8
Shelving	P9
Watering	P10
Fitting liner	P11
Fitting handles	P12
Fitting front & side glass	P14
Fitting corner angles	P15
Fitting back glass	P16
Troubleshooting	P17
Notes on using the frame	P18



#### Video instructions:

Helpful video clips are available at

[www.garden-products.co.uk/instructions](http://www.garden-products.co.uk/instructions)

#### Can we improve?

We hope that you find our instructions clear and concise. If you have any suggestions for improvements email:

[instructionfeedback@garden-products.co.uk](mailto:instructionfeedback@garden-products.co.uk)

Please keep all packaging until installation is complete

Access Garden Products  
Crick  
NORTHAMPTON  
NN6 7XS

Tel: 01788 822301  
Fax: 01788 824256  
[sales@garden-products.co.uk](mailto:sales@garden-products.co.uk)  
[www.garden-products.co.uk](http://www.garden-products.co.uk)

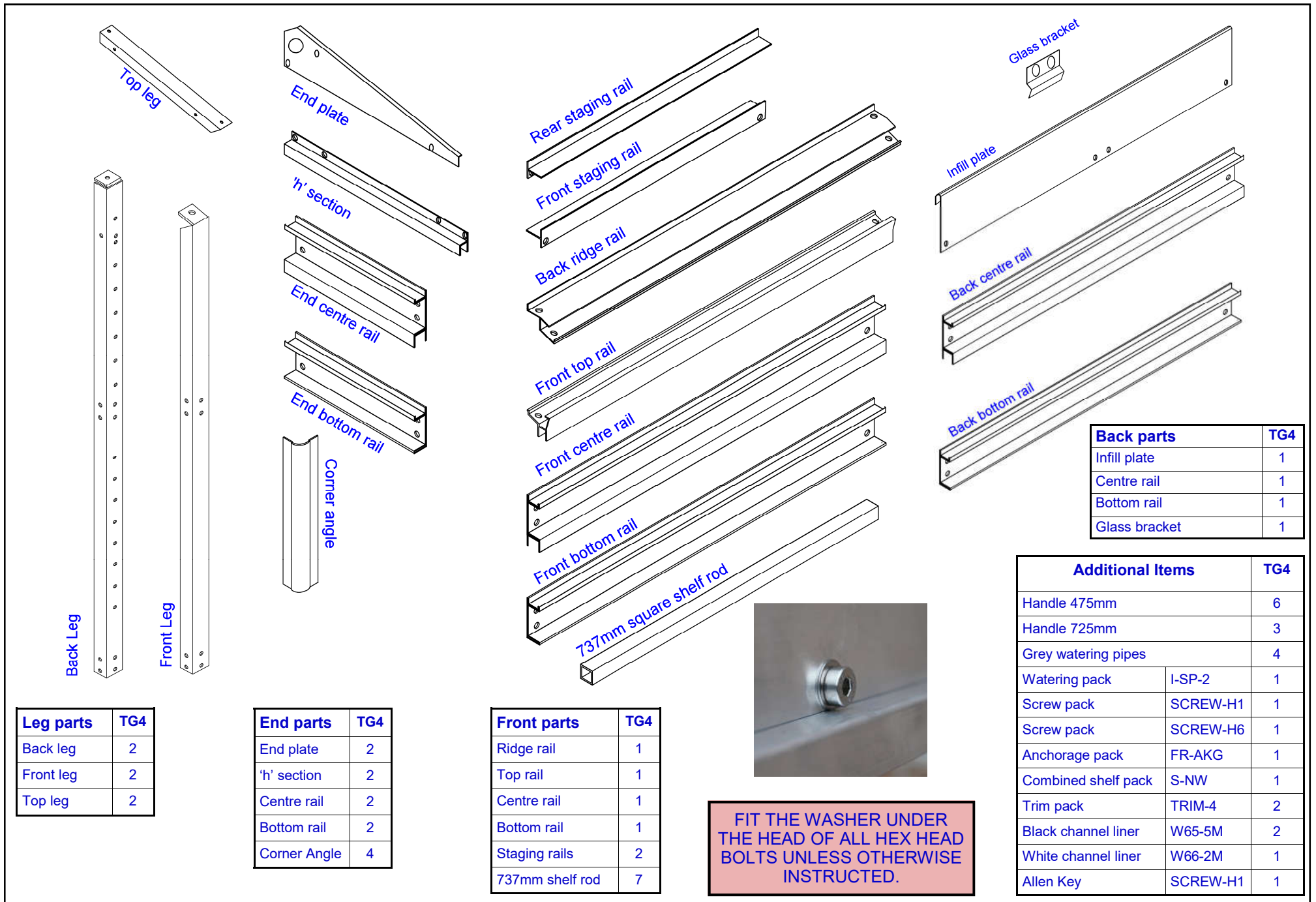

Leg parts	TG4
Back leg	2
Front leg	2
Top leg	2

End parts	TG4
End plate	2
'h' section	2
Centre rail	2
Bottom rail	2
Corner Angle	4

Front parts	TG4
Ridge rail	1
Top rail	1
Centre rail	1
Bottom rail	1
Staging rails	2
737mm shelf rod	7

Back parts	TG4
Infill plate	1
Centre rail	1
Bottom rail	1
Glass bracket	1

Additional Items		TG4
Handle 475mm		6
Handle 725mm		3
Grey watering pipes		4
Watering pack	I-SP-2	1
Screw pack	SCREW-H1	1
Screw pack	SCREW-H6	1
Anchorage pack	FR-AKG	1
Combined shelf pack	S-NW	1
Trim pack	TRIM-4	2
Black channel liner	W65-5M	2
White channel liner	W66-2M	1
Allen Key	SCREW-H1	1



**FIT THE WASHER UNDER THE HEAD OF ALL HEX HEAD BOLTS UNLESS OTHERWISE INSTRUCTED.**

# MAIN ALUMINIUM PARTS



Top leg rests against the **FLAT FACE** of back leg—it is not bolted to the back leg



Back leg the wrong way round

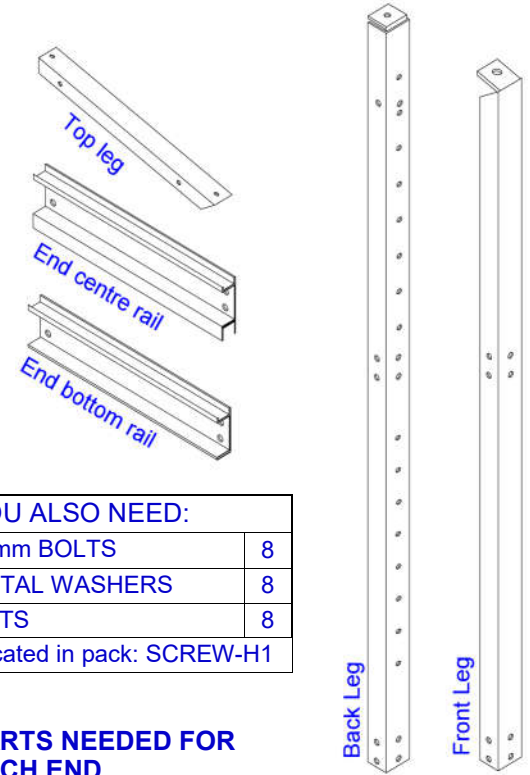

**YOU ALSO NEED:**

10mm BOLTS	8
METAL WASHERS	8
NUTS	8
Located in pack: SCREW-H1	

**PARTS NEEDED FOR EACH END**

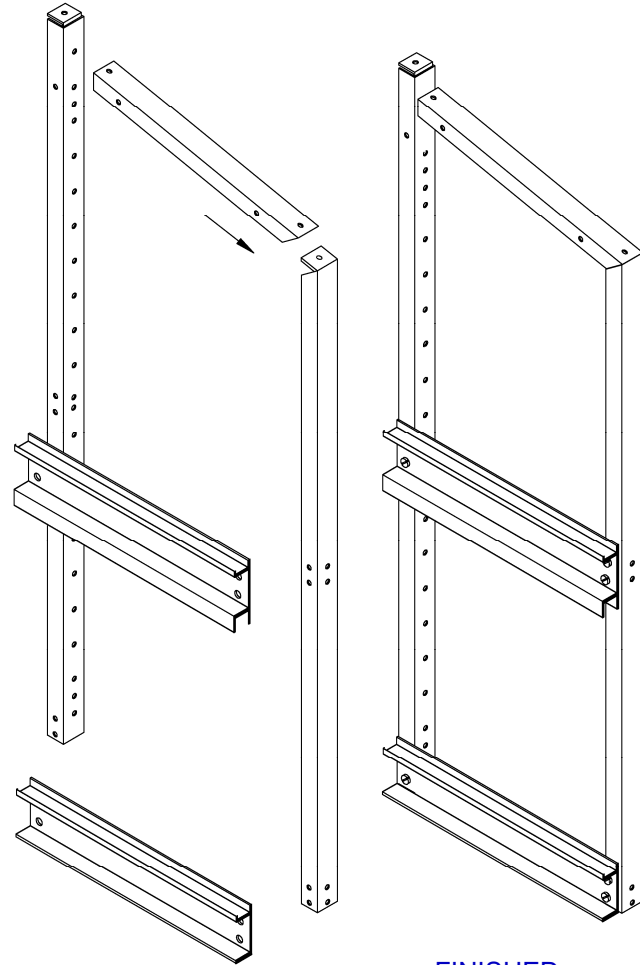

EXPLODED VIEW

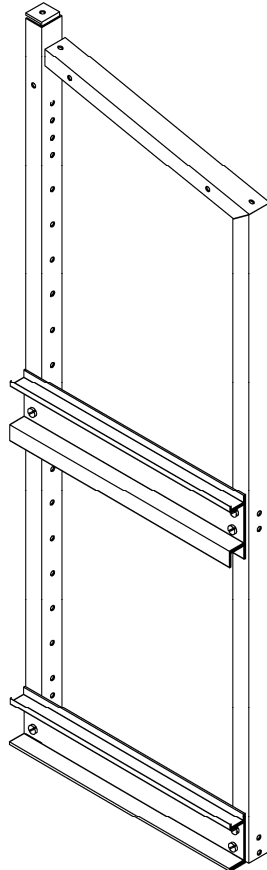

FINISHED LEFT HAND END

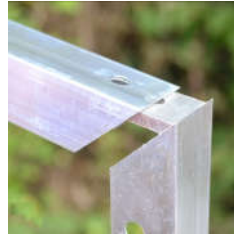

Slide the tongue of the front leg into the groove on the top leg.



DEEPER CHANNEL AT BOTTOM

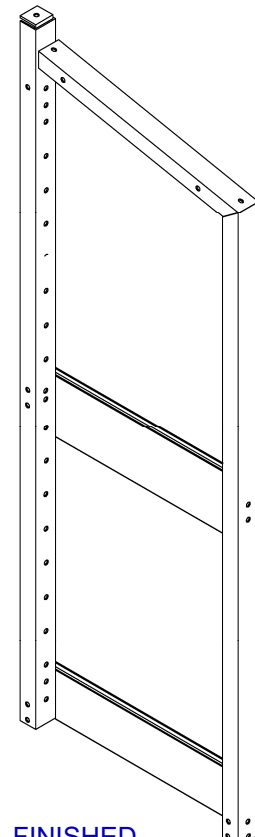

FINISHED RIGHT HAND END



ANCHORAGE BRACKET FITTED

- 1 Make up the LEFT hand end as shown.
- 2 Make up the RIGHT hand end as shown

**DO NOT FULLY TIGHTEN BOLTS AT THIS STAGE**

## END SECTIONS



FIXING DETAIL

DO NOT FIT A WASHER AT THE 4 POINTS MARKED X  
IF POWDERCOATED TAKE CARE NOT TO OVERTIGHTEN BOLT AS WILL DAMAGE PAINT

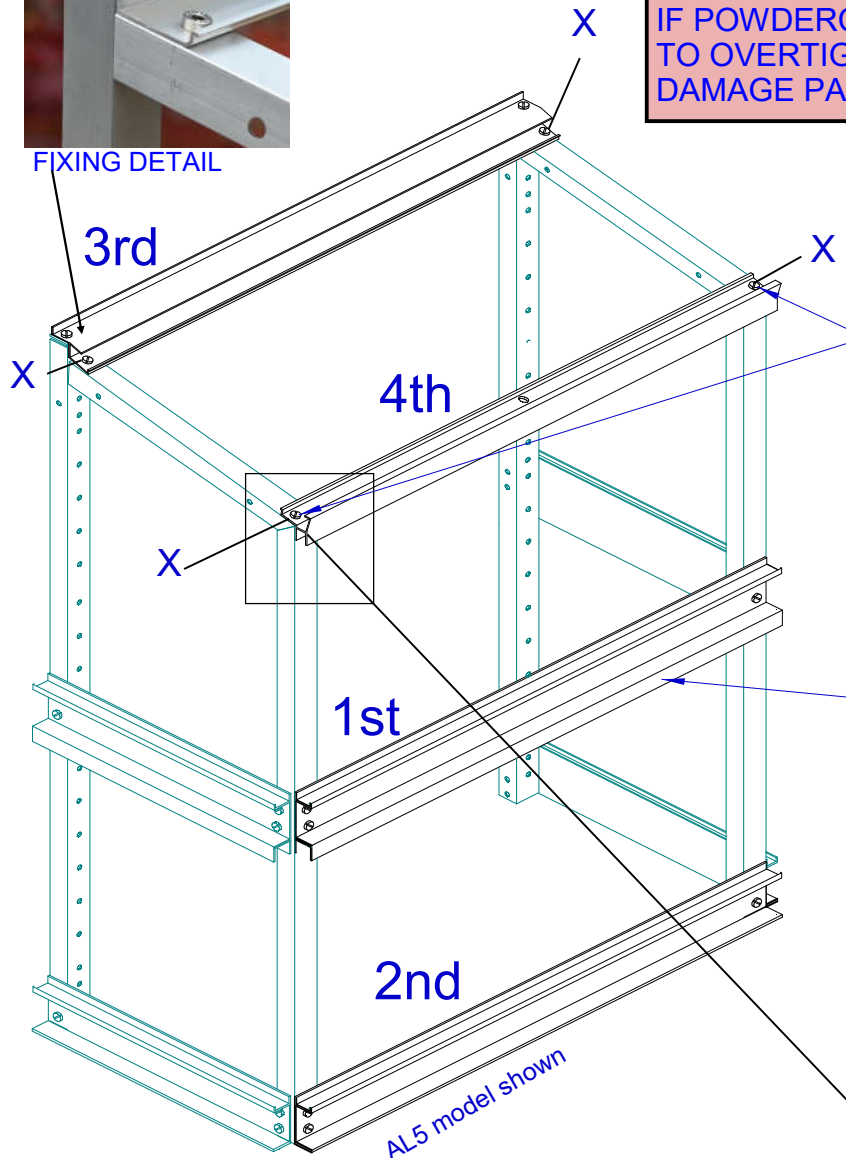

USE THE TWO 20MM BOLTS WITH THIS RAIL



THE DEEPER CHANNEL GOES AT THE BOTTOM



FIXING DETAIL

AL5 model shown

PARTS NEEDED

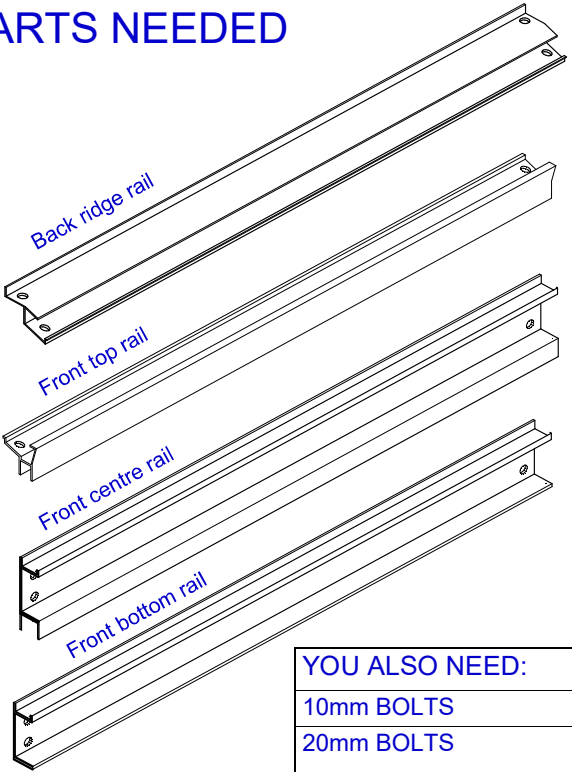

YOU ALSO NEED:	
10mm BOLTS	10
20mm BOLTS	2
METAL WASHERS	10
NUTS	14
Located in pack: SCREW-H1	

1 Bolt on the rails in the order shown. On rail 1 only bolt through the lower two holes. Leave the upper two holes unbolted at this stage.

DO NOT FULLY TIGHTEN BOLTS AT THIS STAGE

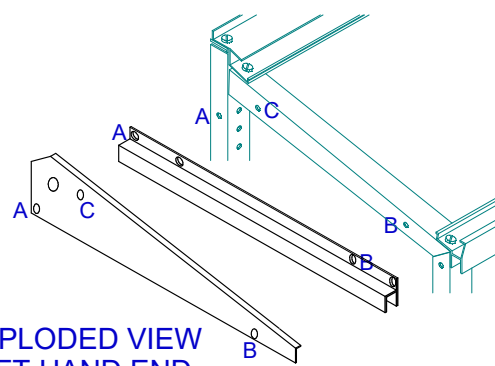

EXPLODED VIEW  
LEFT HAND END

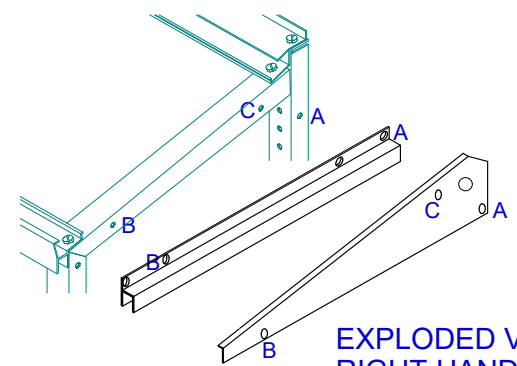

EXPLODED VIEW  
RIGHT HAND END

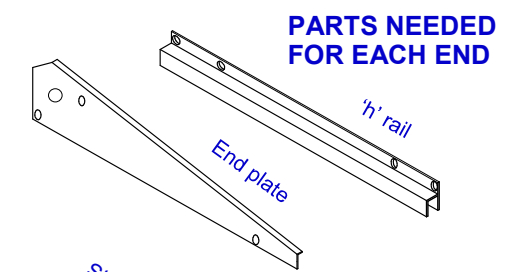

**PARTS NEEDED  
FOR EACH END**



**YOU ALSO NEED:**

10mm BOLTS	3
METAL WASHERS	3
NUTS	3
Located in pack: SCREW-H1	



THE END PLATE  
FITS UNDER THE  
RIDGE RAIL LIP

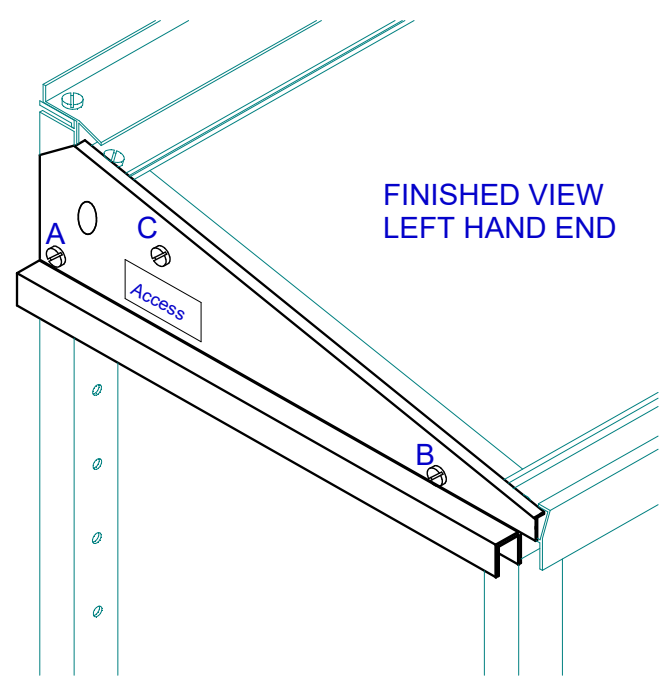

FINISHED VIEW  
LEFT HAND END



THE END PLATE  
FITS UNDER THE  
FRONT RAIL LIP

- 1** Remove any plastic protective film from the end plates and put 'Access' sticker on.
- 2** Make up the LEFT hand end as shown.
- 3** Make up the RIGHT hand end as shown.

**NB** Bolt 'C' only goes through the end plate and the frame.

**DO NOT FULLY TIGHTEN  
BOLTS AT THIS STAGE**



# 1 SQUARING THE FRAME

Use a piece of glass to square the unit as shown. Slacken the nuts if necessary to move the framework into a square position.

Once the frame is completely square tighten up all the nuts.

Remove glass once squaring is complete.

**FULLY TIGHTEN ALL BOLTS**

**PARTS NEEDED**  
Front anchorage pack FR-AKG x 1

If this nut turns while tightening, use a small pair of pliers to hold the nut

**WEAR APPROPRIATE SAFETY EQUIPMENT WHEN DRILLING OR HAMMERING**

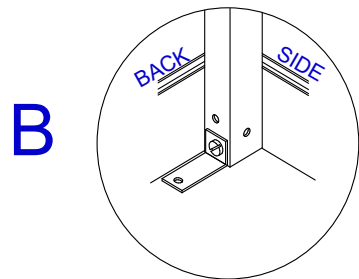
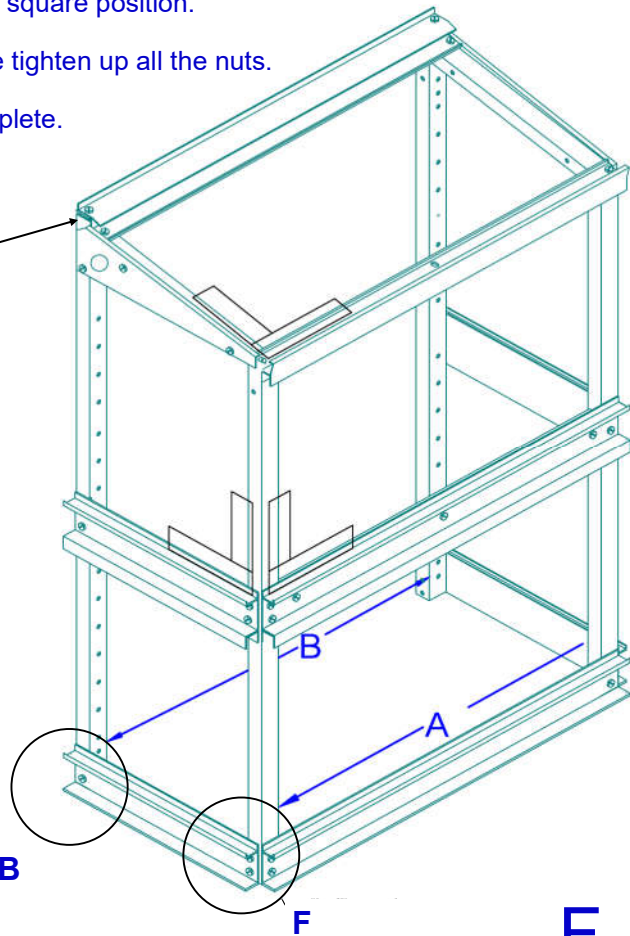

**B**  
INSIDE VIEW OF BACK LEG SHOWING FIXING

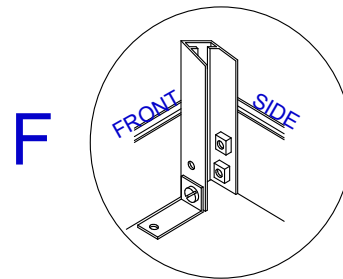

**F**  
INSIDE VIEW OF FRONT LEG SHOWING FIXING

# 2 FIXING TO FLOOR

Fit the 'L' brackets to the front legs using a nut and bolt.

Carefully lay the frame on it's front and fit the 'L' brackets to the back legs using a nut and bolt.

Place the framework in its final position and drill through the bracket with a 6mm masonry drill bit, to a depth of 35mm. Insert the red rawplug, through the bracket and into the concrete.

Using a woodscrew, screw through the 'L' bracket and into the rawplug.

Repeat for other end.

Ensure that the front rail is not bowed before fixing, otherwise the centre staging sheets will not fit. A centre staging sheet can be used to check—see page 13.



Completed front bracket

## PARTS NEEDED

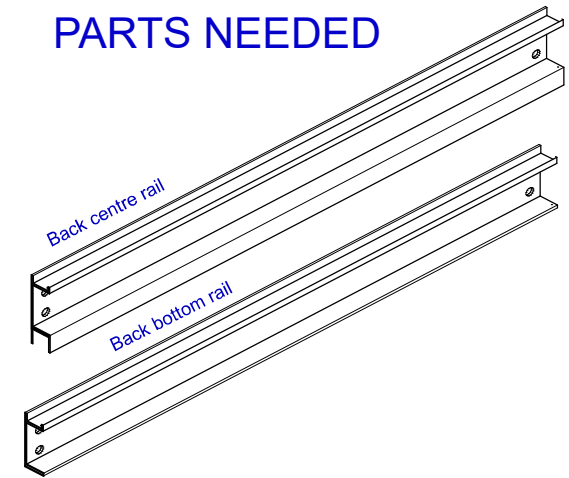

### PARTS ALSO NEEDED

40mm BOLTS	6
METAL WASHERS	6
NUTS	6
20mm NYLON SPACERS	6
Located in pack: SCREW-H6	

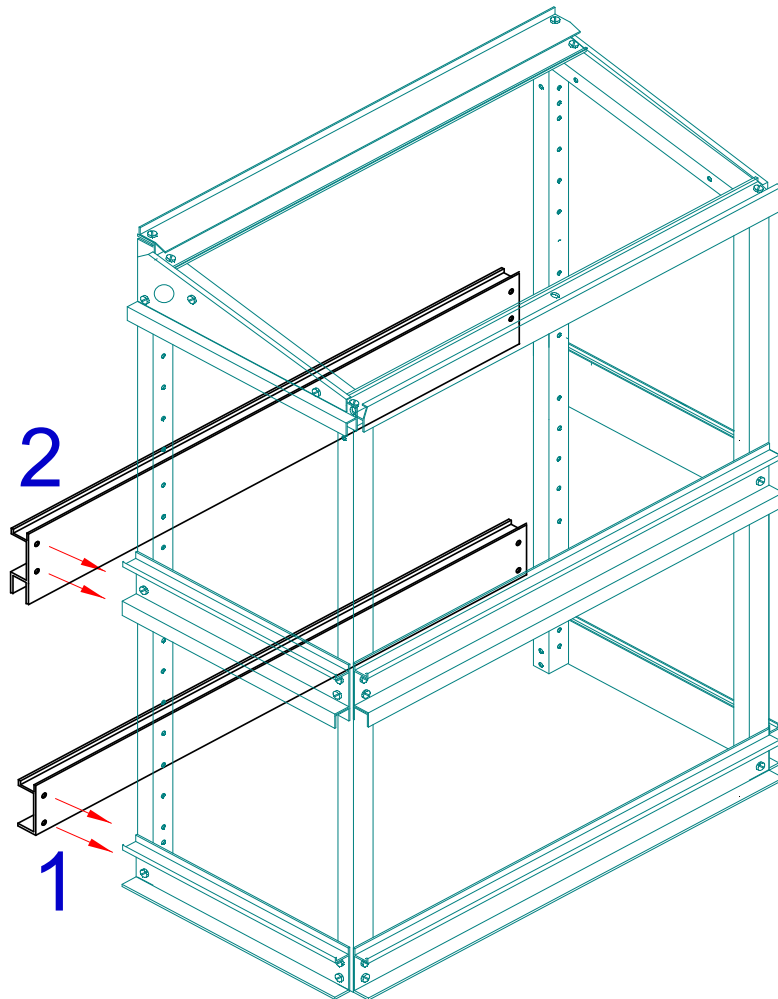

1

**Back bottom rail:** Put a metal washer on the bolt and push the 40mm bolt through the bottom rail. Push a 20mm nylon spacer on to the bolt BEFORE passing the bolt through the frame and fit a nut. Repeat on other holes.

2

**Back centre rail:** Put a metal washer on the bolt and push the 40mm bolt through centre rail **lower** holes. Push 20mm nylon spacer on to bolt BEFORE passing the bolt through the back leg then fit a nut.



Nylon spacer on bolt

**TIP:** If you have purchased the wheel kit, check those instructions now.

**DO NOT FULLY TIGHTEN BOLTS AT THIS STAGE**

## CENTRE & LOWER BACK RAILS

## PARTS NEEDED

### YOU ALSO NEED:

40mm BOLTS	4
METAL WASHERS	4
20mm NYLON SPACERS	4
NUTS	4
In pack: SCREW-H6	

HOLE B OBSCURED

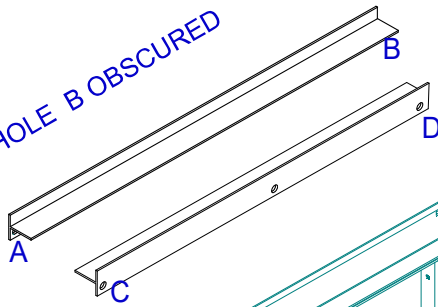

Centre staging rails must have fixing bolt holes on the underside

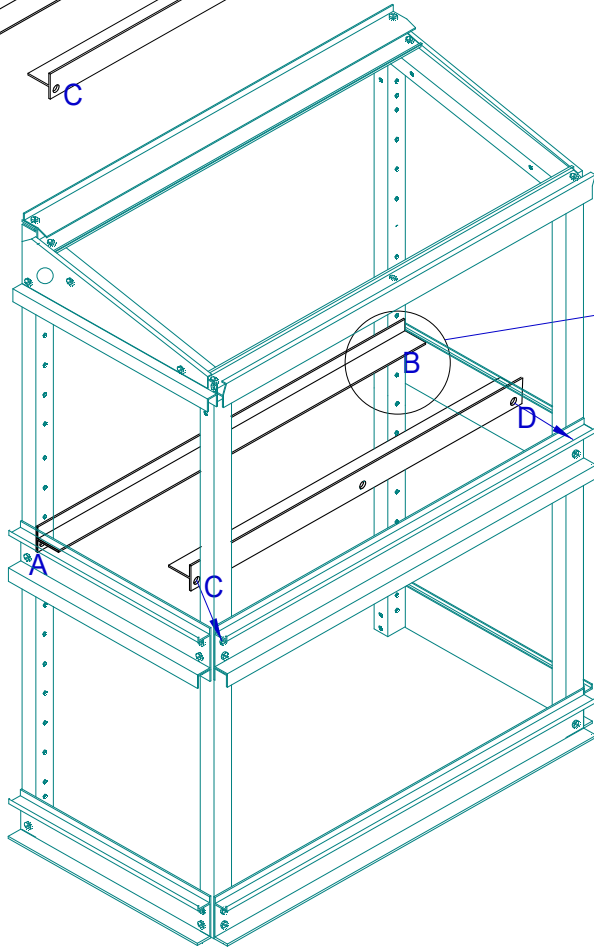

1

POSITION THE RAILS INSIDE THE FRAME AS SHOWN. BOLT THROUGH HOLES SHOWN

**Front rail:** Put a metal washer on the bolt and push the 40mm bolt through the centre rail **upper** holes. Slide on nylon spacers, then the front staging rail before refitting the nuts.

**Back rail:** Put a metal washer on the bolt and push the 40mm bolt through the centre rail **upper** holes. Push 20mm nylon spacer onto the bolt before passing the bolt through the back leg. Fit the support onto the bolt then fit a nut.



**1** Remove the plastic protective film from the infill plate and end glass bracket.

Put a metal washer on the 10mm bolt which goes through the infill plate from the outside at hole 'E'. Put a 3mm white spacer on each bolt before pushing on the glass bracket, then fit the nut. Glass bracket is INSIDE frame and will clamp onto the glass once the glass is in place.

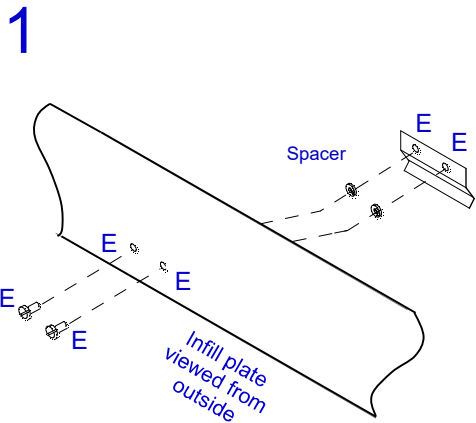

Completed bracket inside Greenhouse

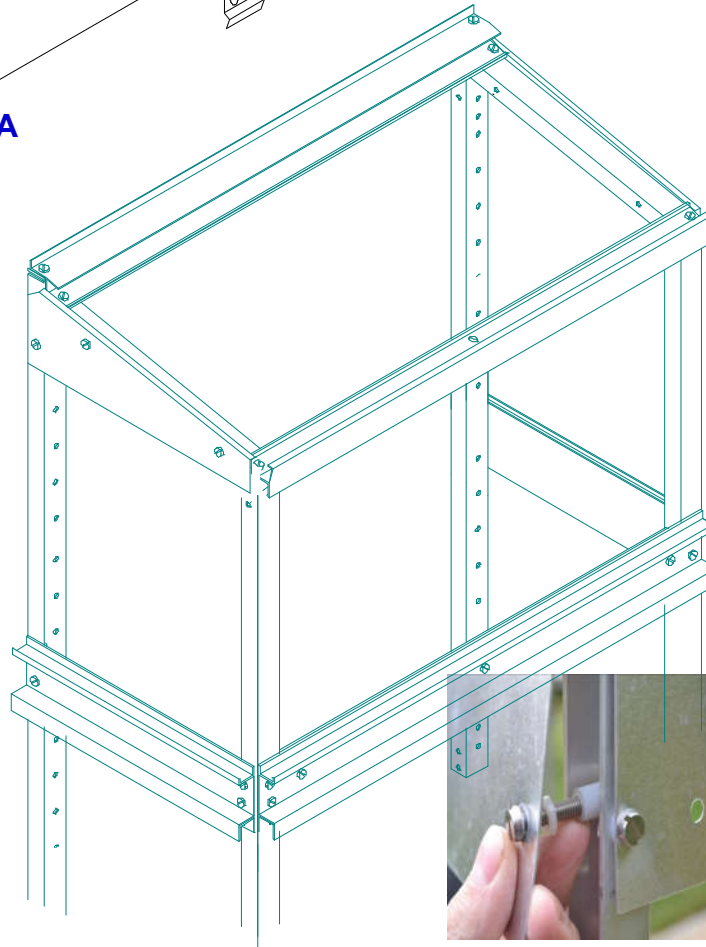
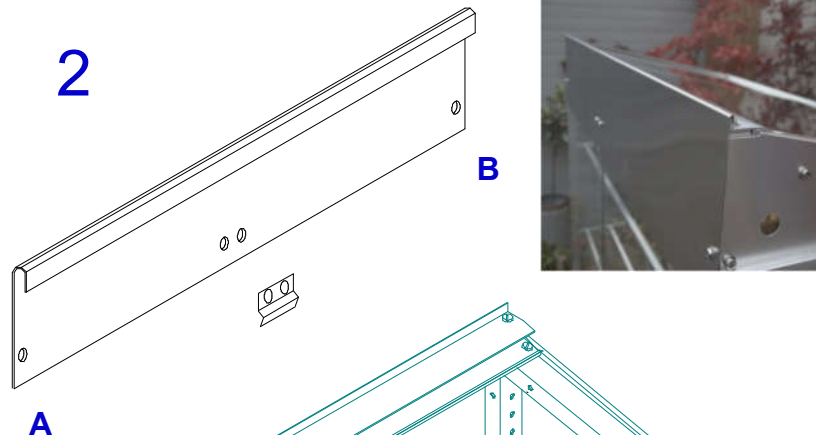

White spacers on infill plate

**PARTS NEEDED**

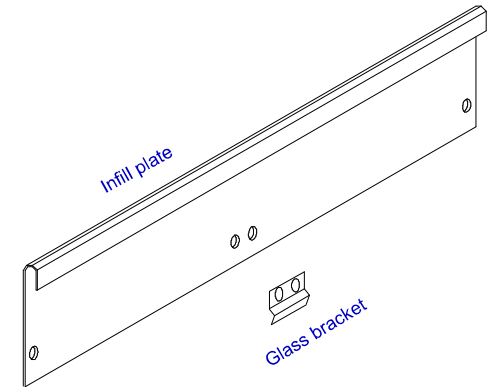

**PARTS ALSO NEEDED**

10mm BOLTS	2
40mm BOLTS	2
METAL WASHERS	4
NUTS	4
20mm WHITE SPACERS	2
3mm WHITE SPACERS	2
Located in pack: SCREW-H6 and H1	

**2** Place the lipped section over the upstand on the back rail. Push a long 40mm bolt and metal washer through hole A, then fit a white 3mm spacer and a 20mm nylon spacer. Push the bolt into the frame and fit a nut on the inside of the frame. Repeat for hole B at the other end.

The TG4 model has 1 standard  
+ 1 wide full length shelf

Standard shelves must be used  
adjacent to the louvre vent  
(optional).

### FITTING

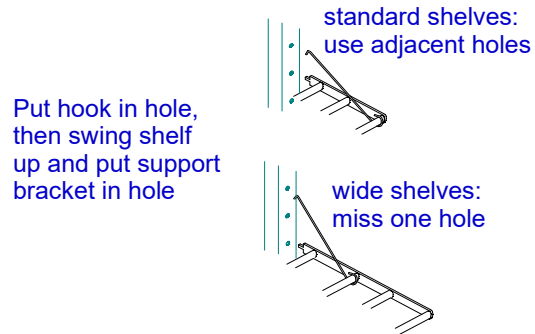

Hook support wire into top hole, then swing shelf upward into the hole. Make sure flat face of shelf rod is uppermost.

### PARTS NEEDED

Square rod profile  
Flat face is uppermost

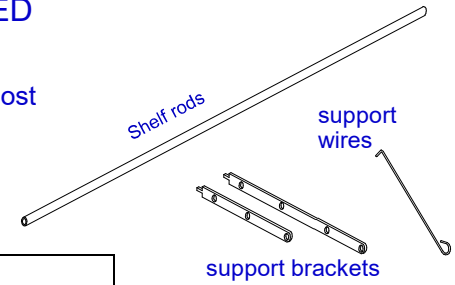
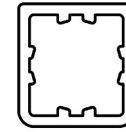

#### YOU ALSO NEED PER SHELF ROD:

RAWLPLUGS	2
WOOD SCREW	2
Located in packs: S-NW	

#### YOU ALSO NEED PER COMPLETE SHELF:

NYLON SPACER	2
Located in packs: S-NW	

#### 5-hole strap (wide)

Fit the rods to the holes 'F' - the rod with support wire is  
marked SW. The centre hole is unused.

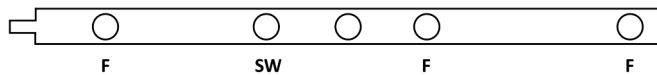

The large number of holes in the back leg  
allow the spacing of the shelves to be easily  
altered.

When the shelves are not needed they can  
either be removed or they can be unhooked  
from the lower fixing hole and hung flat  
against the back using the wires.

- 1 Lightly tap rawlplug inserts into both  
ends of the tubular aluminium shelf  
rods with a hammer.
- 2 Screw the support brackets on to  
each end EXCEPT for the rod that  
has the support wires.
- 3 For the rod with the support wires put  
the spacer and the support wire onto  
the screw BEFORE passing through  
the bracket.

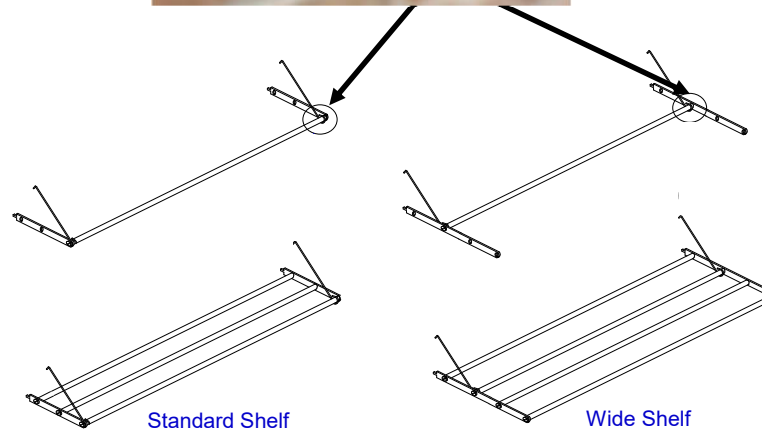

Note: A Pozidrive screwdriver will fit the screws best



Bottom shelf hung flat against the back

**1** Choose which end you would like the watering inlet.



Fit the washer onto the thread of the adaptor, and then fit the nipple



Push the assembly through the hole from the inside



Screw the brass elbow onto the protruding thread from the outside

**Right hand watering entry:**

The double tee is configured for fitting to the left hand end. To change to r/h entry, twist the tee through 180 degrees.

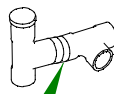

Twist here for r/h end fitting

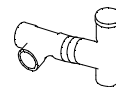

Finished tee for r/h end fitting



**PARTS NEEDED:**

NOZZLE ASSEMBLY	2
SINGLE TEE	2
BLANKING PLUG	4
DOUBLE TEE	1
'L' BRACKET	2
GREY PIPES	4
ENTRY FITTING	1
10MM BOLTS & NUTS	2
BLACK STRAPS (short)	6
Located in pack: I-SP-2	

**2** 'L' brackets need to be fitted inside the frame.  
x - Use a nut and bolt to fix to the hole  
y - Use the bolt hole on the centre staging rail

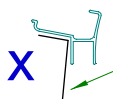
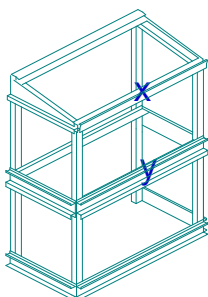

Use black strap through hole to fix pipework to bracket.

**Y**



Bend bracket down

**3** Fit the irrigation system as shown. The grey tubes push into the black fittings. Ensure the open face of the grey nozzle faces into the frame.

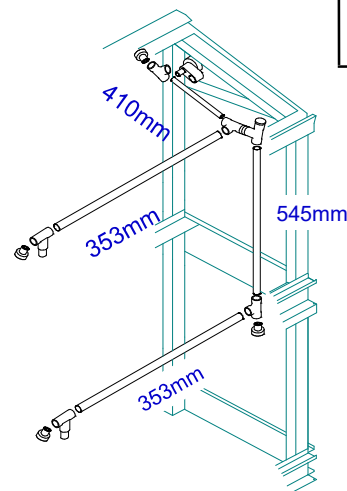

**TIP:** Dip the end of the grey pipe in water. For a better fit, twist the pipes as they are inserted.

**4** Use the black straps to secure the watering system to the 'L' shaped brackets and then strap the pipes to the end of the frame using the hole in the leg.

Fit the black grommet (from pack SCREW-H1) into the unused irrigation hole at the opposite end of the unit.



Blanking grommet

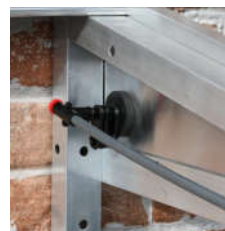

Inlet and link pipe

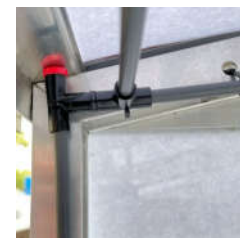

Double tee

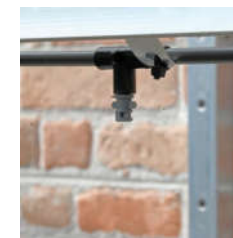

Nozzle strapped to 'L' bracket

# FITTING THE CHANNEL LINER

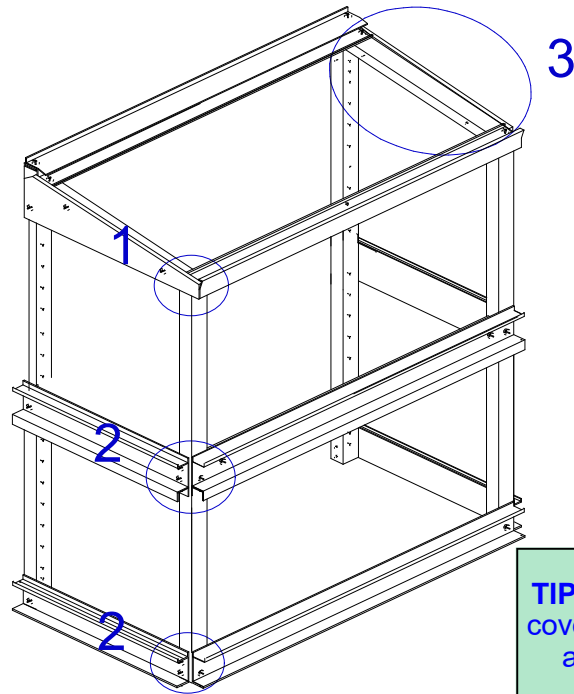

1

The white liner (W66-2M) fits on the inside vertical face of top FRONT rail only. This is a loose fit so strips of double sided tape are included to secure it until the glass is in place.

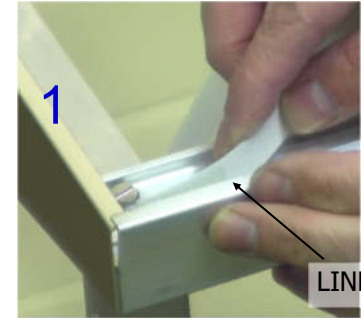

Before sticking the tape, clean the aluminium of any oil traces to promote adhesion.

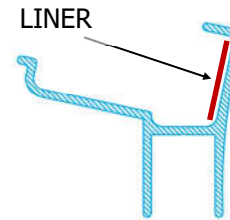

2

The black plastic liner (W65-5M) goes in the FRONT bottom and centre rails only. Using the strips of double sided tape press liner down so that it LIES FLAT at the bottom of the channel - trim with a knife if necessary.

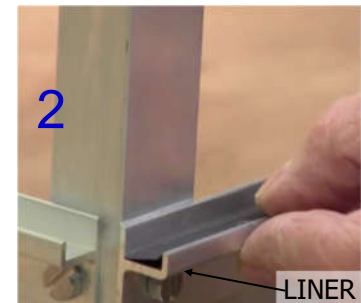

THE DOORS WILL NOT SLIDE PROPERLY IF THE LINER IS NOT FLAT

**TIP:** Do not use the red covered sticky pads that are for the handles

3

To make the top glass slide more easily, rub candle wax onto the glass bearers. Also wax the black and white liners.

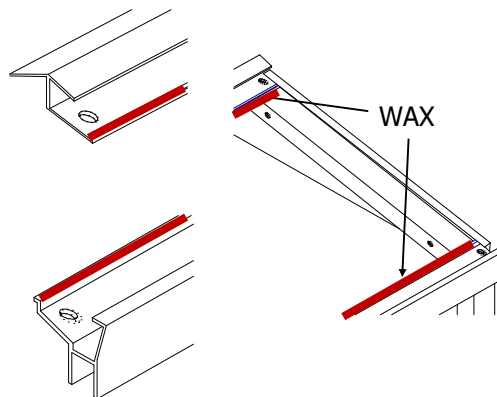

## Removing the tape

Peel the **narrower** backing tape off first, this will expose the sticky pad, allowing it to be stuck onto the liner.

**Tip:** Bend the backing tape back on itself to make it easier to peel the sticky pad off.

Place pads regularly down the length of the liner.

When ready, peel the **wide** backing pads off the tape and stick the liner to the aluminium.



On the next page are instructions on how to fit the handles to the glass

When fitting the handles, place the glass on a table or timber battens.

**NEVER PLACE THE GLASS DIRECTLY ON CONCRETE OR SLABS**

**DO NOT** lift the glass by the handle

If possible, leave the handles overnight in a warm place to promote the curing of the adhesive

**TIP:** Always grip the handle in the **CENTRE** when sliding

**WARNING**

If broken, toughened glass will fragment safely.

If the edges are knocked or chipped the glass will spontaneously fragment. This is a natural occurrence due to the toughening process. Care should be taken when moving or cleaning, not to damage the edge of the glass.

When placing the glass in the frame, ensure that the glass is securely placed in the runners before letting go of the glass.

SEE PAGE 14 FOR WHICH GLASS SHEETS NEED HANDLES	'C' sheet	'D' sheet	'E' sheet
Sheets requiring one handle	1	1	1
Sheets requiring two handles	1	1	1

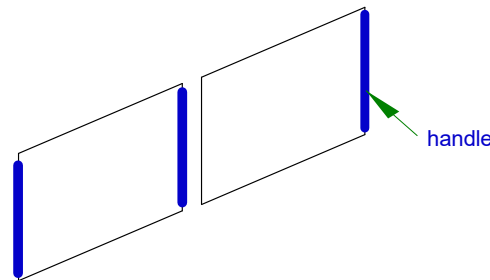

**HANDLES**

The right hand glass sheets always have 1 handle.

The left hand glass sheets always have 2 handles.

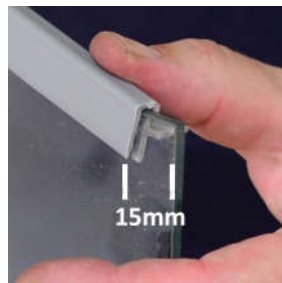

Work on handle from side edge



Handle fitted with 15mm gap



Sheet with 2 handles



Sheet with 1 handle





1

Ideally work on a table or a workbench.

It is best to work inside to keep the pads warm and dry.



2

Mark the glass 15mm from the top edge for sheets.



3

Open the sachet and wipe the glass where the tape will stick.



4

Replace the cloth in the plastic bag to prevent evaporation.



5

Peel the pad off the backing.

Short handles have 2 pads (top and bottom). Long handles have 3 pads (plus centre).

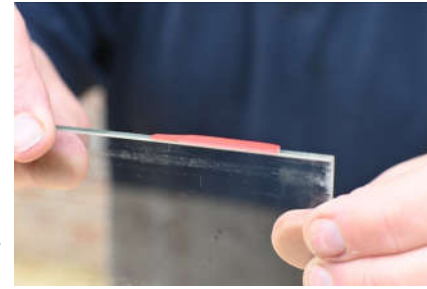

6

Press the pad down firmly to ensure good adhesion to the glass.

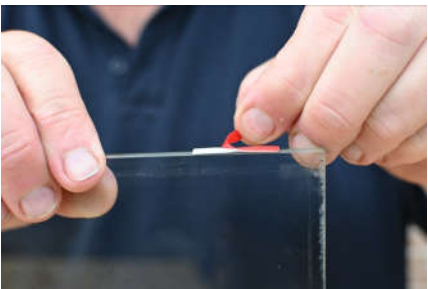

7

Peel the cover strips off all of the pads.



8

Using the pen mark as a guide, fit the handle.

Slide the two arms of the 'U' over the edge of the glass.



9

Work the handle on with your hands.



10

Use one of the glass battens to gently tap the handle down.



11

Work the handle on all the way down the glass.

Use the timber batten if necessary.



12

Use the timber to make sure the handle is flat.

Leave overnight in the warm to fully cure the adhesive

### CENTRE STAGING (F)

If you wish to fit the staging glass (453mm x 353mm) sheets place these on the centre staging rails before glazing the frame. Centre staging is in glass packs GT-TG2.

### FITTING HANDLES

Fit the handles to the glass before fitting into the frame. Right hand panels always have a single handle on the right hand side of the sheet. Left hand panels have two handles, one on each side.

### FITTING THE FRONT & SIDE GLASS

To fit the glass push the sheet into the deeper top channel, then lower into the bottom channel (A). Make sure the glass is firmly in the bottom channel before letting go. When putting the sheets in the frame, put the first sheet in at the right hand end. The second sheet will fit in front of the first sheet and overlap the first panel by approx. 1" (2cm).

### SLIDING THE FRONT GLASS

When closed, both panels will tuck behind the corner trims to keep them secure. Before sliding the right hand panel open, slide the left hand panel open by approx 1" to release it from behind the corner trim.



F. Centre staging fitted



A. Fitting the glass

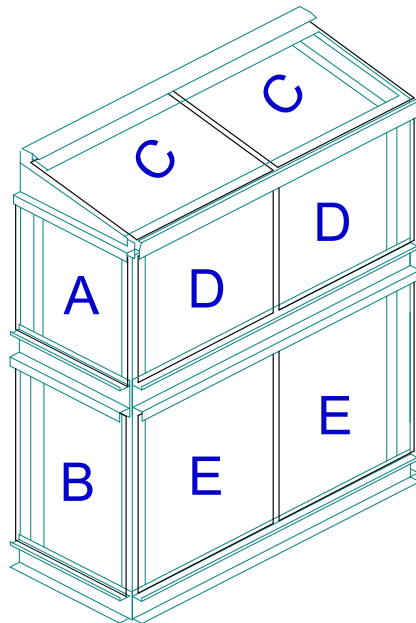

FRONT & SIDE GLASS		
A	500mm x 500mm	Qty: 2
B	750mm x 500mm	Qty: 2
C	500mm x 400mm	Qty: 2
D	500mm x 400mm	Qty: 2
E	750mm x 400mm	Qty: 2
F	453mm x 353mm	Qty: 2
End glass (A & B) have no handles		

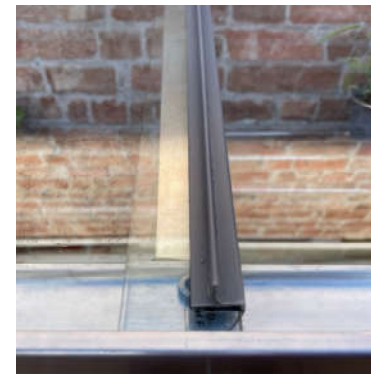

Roof glass overlapping



Glass in channel with two sheets overlapping

## BLACK 'WEDGES'

The small black thimble wedges (w) are designed to be pushed into the top channels of the end glass to stop the glass moving. Use two wedges per sheet of glass



Located in: ALL SCREW PACKS



Corner trim in place

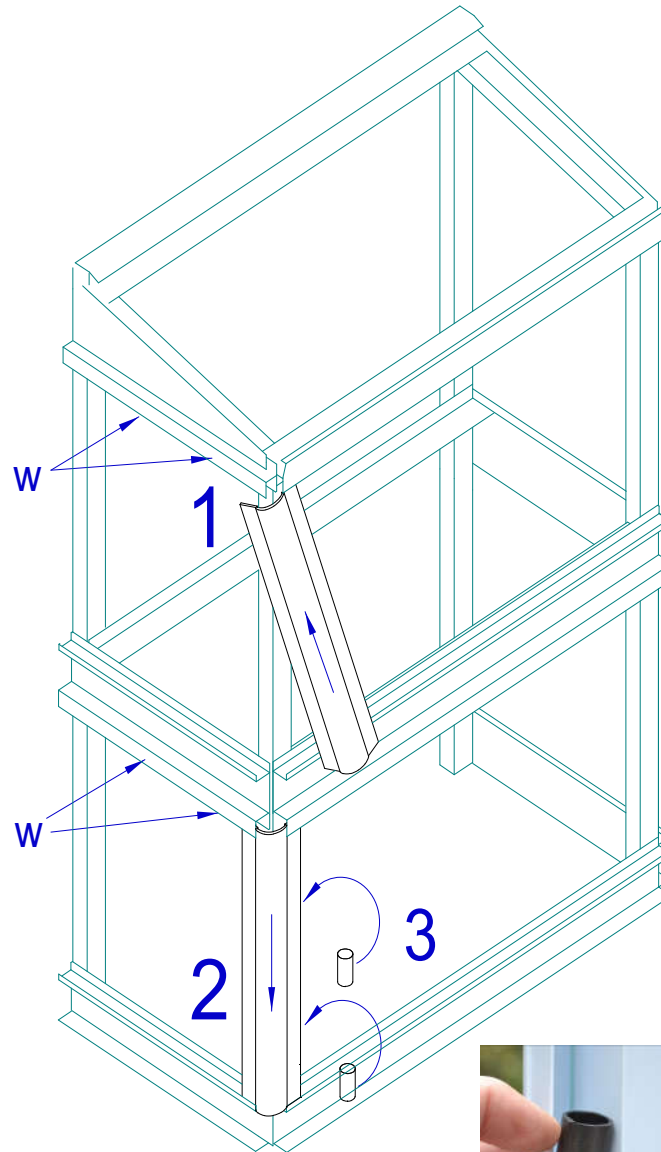

**NB—NO CORNER ANGLES  
REQUIRED FOR BACK OF FRAME**



Fitting the hollow tube

## Aluminium corner trims

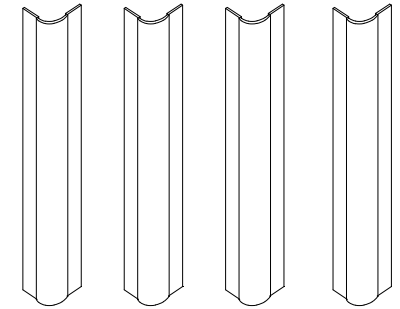

You also need: 2 bags  
marked as TRIM-4 x 2

## PARTS NEEDED



- 1 Take one of the corner trims and push it up into the top channel and the 'h' section.
- 2 Swing the corner trim in so that it is vertical and drop it into the channel below. At this point the trim will be loose.
- 3 Slide the front glass door out of the way. Take one of the hollow tubes contained in the pack marked 'TRIM'. From the front of the frame, push the tube between the framework and the corner trim. Slide the tube downwards as far as it will go.  
  
Insert a second hollow tube and repeat the action, but this time push the tube up as far as it will go.  
  
These tubes keep the corner trim firmly in place, and act as a stop for the sliding doors.
- 4 Repeat for the other 3 corners



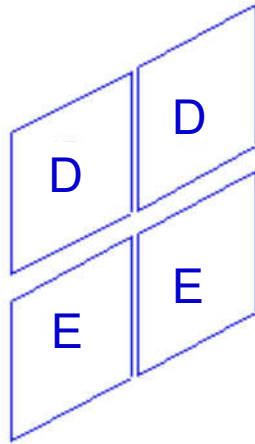

BACK GLASS		
D	500mm x 400mm	Qty: 2
E	750mm x 400mm	Qty: 2

### TOP BACK GLASS

Slacken the four infill plate bolts and gently slide the first sheet in from the rear corner. Gently slide the other sheet in from the other end. The two sheets will overlap in the centre, behind the glass bracket (B). Carefully retighten the bolts. Fit a ring wedge (F) into the bottom glass channel - 1 per sheet.

### BOTTOM BACK GLASS

Fit the glass using the same method as the front glass. In the centre of each pane, push a black thimble shaped wedge into the top glass channel to prevent the glass rattling (D). Fit a ring wedge (F) into the bottom glass channel - 1 per sheet.

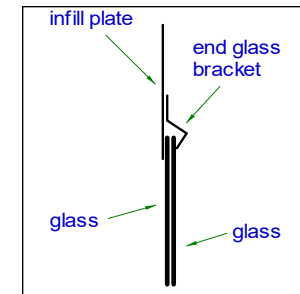

B. Top back glass overlap detail

B. Glass bracket



D. Thimble wedge



F. Ring wedge

<b>CORNER TRIMS WILL NOT FIT</b>	The most common cause of this problem is the end glass protruding over the front leg. This is normally caused because the frame work is not square against the wall. See page 7.
<b>GLASS STICKS TOGETHER</b>	This is normally due to the handles not being put on the right side of the glass. See page 12 for details of where the handles should be fitted to the glass.  If the glass has stuck together, push the two sheets to the back of the channel, then slowly pull the front sheet of glass forward from one end. This will release the suction between the sheets.
<b>HANDLES COME OFF</b>	If handles come off frequently either purchase some new handles and sticky pads from Access or use a glue such as 'liquid nails' or 'no more nails' to permanently glue the handles to the glass.
<b>SHELVES WILL NOT FIT INTO THE BACK LEGS</b>	Check that the back legs have been fitted the right way round - see page 2. Check that dimension A = B - see page 7.
<b>LOUVRE VENT DOES NOT FULLY CLOSE ON COLD DAYS</b>	Loosen the two screws which hold the automatic opener to the vent. Push the opener up as far as it will go. Retighten the 2 screws.  If the unit still does not fully close, lubricate the opener mechanism and all the pivot points with WD-40
<b>GLASS FALLS OUT OF THE LOWER LEVEL</b>	Ensure that the centre rail has the deeper channel at the bottom.
<b>WATERING INLET LEAKS</b>	Try tightening the inlet fitting as it needs to be tight to seal.



## **PERIODIC MAINTENANCE**

Every Spring take the glass out of the greenhouse and wash glass and framework with warm soapy water.

Lubricate the automatic louvre vent bi-monthly and remove if subject to very heavy frosts.

When inserting the glass, always check that the glass is properly seated in its top and bottom channels before letting go of the sheet.

**CHECK THE TIGHTNESS** of all bolts regularly, especially in very windy areas or powder coated frames.

**CROP ROTATION** Suggestions for suitable crops and sowing dates given in the free Access Growing Guide

**VENTILATION** In cold weather gentle ventilation can be given by sliding the four front sheets of glass to give 2-3" (5-8cm) gap at each corner.

In warmer weather allow a gap on the top sheets as well. In very hot weather open all the sheets of glass.

To ensure that the correct temperature is maintained use a thermometer inside the greenhouse. You can completely remove the top sheets in summer. Access shading will help keep temperatures down, and stop birds etc getting inside. The Access Automatic Vent will look after ventilation - automatically!

**GALES** The greenhouse must be kept fully closed in rough weather.

**GLASS CHANNELS** Ensure that this is kept free from debris and allows the glass to slide smoothly. Periodically lubricate the running edge of the glass with a wax candle.

**SNOW** If snow is very heavy - avoid letting it build up on the roof

**SHELVING** Stand pot plants on saucers, or use optional shelf covers which incorporate a layer of capillary matting to absorb excess water when watering. Alternatively, stand the pots in empty seed trays.

**CENTRE STAGING** To accommodate tall plants slide one sheet over another or lift out completely.

**WATERING SYSTEM** The system accepts standard quick connectors. Turn the tap on slowly until the mist fills the greenhouse; too much pressure will throw water on to the back wall. Leave on for 5 minutes, or ½ minute for damping down.

**SITING** Site on the sunniest place available. Anything from East through South to West is suitable. If it has to face North, don't despair, it will be warmer in than outside! If you can fix to a brick or stone wall, you will get extra heat storage during the day.

**REDUCING THE LENGTH** If it is just too long for your ideal spot, it can be shortened. Re-drill the holes at one end of the rails - moving them in by the amount you need to remove. Hacksaw off the surplus aluminium and shorten the shelf rods and irrigation pipe. The glass will merely overlap more - don't try to cut toughened glass!